



The basics of surge protection

From the generation of surge voltages
right through to a comprehensive protection concept

In dialog with customers and partners worldwide

Phoenix Contact is a global market leader in the field of electrical engineering, electronics, and automation. Founded in 1923, the family-owned company now employs around 14,000 people worldwide.

A sales network with over 50 sales subsidiaries and 30 additional global sales partners guarantees customer proximity directly on site, anywhere in the world.

Our range of services consists of products associated with a wide variety of electrotechnical applications. This includes numerous connection technologies for device manufacturers and machine building, components for modern control cabinets, and tailor-made solutions for many applications and industries, such as the automotive industry, wind energy, solar energy, the process industry or applications in the field of water supply, power transmission and distribution, and the transportation infrastructure.

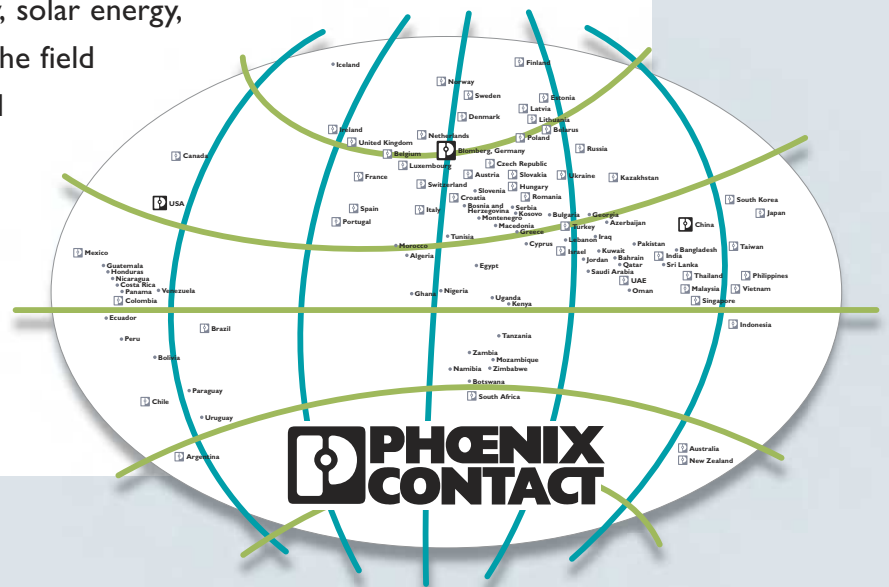



The basics of surge protection

We don't just want to support you with convincing solutions, but also to be on hand with help and advice. This includes basic information on the topics of technology and electronics that applies to all of us. In this brochure, you will gain an insight into the field of surge protection. Discover the most important facts in a nutshell. Discover what solutions there are for the diverse challenges facing this sector. Or deepen your knowledge of the context and background; something only the specialists know.

We wish you – in the truest sense of the word – an exciting read!

The very latest solutions

At Phoenix Contact, particular emphasis is placed on development expertise and a high degree of manufacturing capability. All key technologies, from full engineering, to tool manufacturing, metal processing, and plastic production, right through to electronics development and manufacturing are all available in-house. Since 1983, Phoenix Contact has developed and manufactured surge protective devices and today is the technology leader in this area. The company provides many innovative solutions for every industry and application, among others, for

- Power supply
- Measurement and control technology
- Data technology and
- Transceiver systems

The many years of experience in this area means Phoenix Contact excels, both in development and manufacturing. The accredited in-house lightning and high-current laboratory, the most sophisticated in the world, is just part of this. It lays the foundation for precise, constantly adjusted test procedures and basic research tailored to the application – and can therefore be implemented for solutions using current findings from theory and practice.

Essentially, products with the highest quality levels and cutting-edge technology.

Questions and answers

You probably have a great deal of questions – ranging from basic queries as to how surge voltages even occur, to technical details about grid systems or individual components of a surge protection concept, right through to the device itself. Here you can refer to:

**What is a surge voltage?
How does it occur?**

→ Section 1, Page 6

**What damage can surge voltages
cause?**

→ Section 1.5, Page 9

How does surge protection work?

→ Section 2.1, Page 10

**What legal or standard requirements
are there for surge protection?**

→ Section 2.2, Page 11

**What makes up a consistent surge
protection concept?**

→ Section 2.3 et seqq., Page 13

**How can the quality of surge
protective devices be (officially)
verified?**

→ Section 3.3, Page 18

→ Section 4, Page 22

**In which applications is surge
protection particularly important?**

→ Section 6, Page 28

Explanation of terms

→ Section 7, Page 56



Contents

1. Surge voltages	6
1.1 The phenomenon of surge voltage	6
1.2 Causes	7
1.3 Coupling types	8
1.4 Direction of action	8
1.5 Effects	9

2. Surge protection: what should be noted?	10
2.1 This is how surge protection works	10
2.2 Lightning and surge protection standards	11
2.3 Basic protective measures and equipment	13
2.4 Lightning protection zones	14
2.5 The protective circle principle	15

3. Classification and testing of surge protective devices	16
3.1 Requirements according to product standard IEC 61643	16
3.2 Key characteristics for surge protective devices	17
3.3 Maintenance and testing according to IEC 62305	18
3.4 Pulse and high-current testing technology	20

4. Quality features	22
4.1 CE declaration of conformity	22
4.2 Independent product certifications	23
4.3 Expertise in surge protection	24

5. The lightning monitoring system	26
5.1 Smart monitoring	26
5.2 Lightning current detection	27

6. Fields of application	28
6.1 Protection of AC systems	28
6.2 Protection of DC systems with linear voltage sources	40
6.3 Protection of photovoltaic systems	41
6.4 Protection of signal transmission circuits in MCR technology	46
6.5 Protection of signal transmission circuits in information technology	52
6.6 Protection of signal transmission circuits in telecommunications technology	54
6.7 Protection of signal transmission circuits in transceiver systems	55

7. Glossary	56
--------------------	-----------

8. References	59
----------------------	-----------

1 Surge voltages

Various types of surge voltages occur in electrical plants and electronic systems. They are differentiated mainly by their duration and power. Depending on the cause, a surge voltage can last a few hundred microseconds, hours or even days. The amplitude can range from a few millivolts to some ten thousand volts. The direct or indirect consequences of lightning strikes are one particular cause of surge voltages. Here, during the surge voltage, high surge currents with amplitudes of up to some ten thousand amperes can occur. In this case, the consequences are particularly serious. This is because the damaging effect first of all depends on the power of the respective surge voltage pulse.

1.1 The phenomenon of surge voltage

Every electrical device has a specific dielectric strength. If the level of a surge voltage exceeds this strength, malfunctions or damage can occur. Surge voltages in the high or kilovolt range are generally transient overvoltages of comparatively short duration. They generally last from a few hundred microseconds to a few milliseconds. As the maximum amplitude of such transients can amount to several

kilovolts, steep voltage increases and differences are often the consequence.

Surge protection is the only thing that helps. Indeed, the operator of an electrical system generally replaces the material damage to the system with corresponding protection. However, the difference in time between failure of the system to maintenance represents a risk in itself. This failure is often not covered by insurance and, within a short period

of time, can become a heavy financial burden – especially in comparison to the cost of a lightning and surge protection concept.

1.2 Causes

The typical duration and amplitude of the surge voltage varies depending on the cause.

Lightning strikes

It is above all lightning strikes (lightning electromagnetic pulse, LEMP) that have the greatest potential for damage among all the causes of occurrence. They cause transient overvoltages that can extend across great distances and are often associated with high-amplitude surge currents. Even the indirect effects of a lightning strike can lead to a surge voltage of several kilovolts and result in a surge current of tens of thousands of amperes. In spite of the very brief duration – a few hundred microseconds to a few milliseconds – such an event can lead to total failure or even the destruction of the affected installation.

Switching operations

Switching operations (switching electromagnetic pulse, SEMP) can generate induced surge voltages that spread to supply lines. In the case of large switch-on currents or short



Fig. 1: Lightning strikes have an extremely high potential for destruction

circuits, very high currents can flow within a few milliseconds. These short-term current changes can lead to transient overvoltages.

Electrostatic discharges

Electrostatic discharges (ESD) occur if bodies with different electrostatic potential approach each other and result in a charge exchange. A sudden charge

exchange leads to a brief surge voltage. This presents a hazard, especially for sensitive electronic components.



Fig. 2: Electric motors with high power induce surge voltages due to high switch-on currents

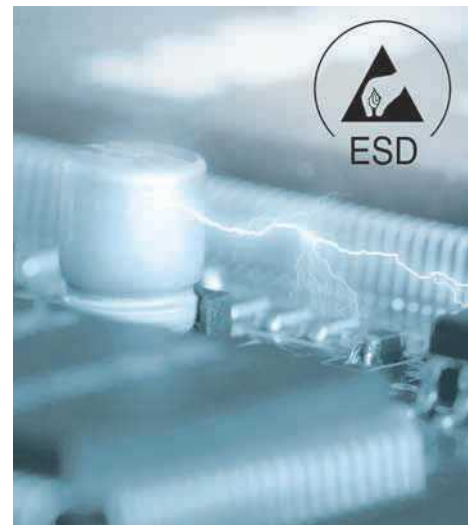

Fig. 3: Electrostatic discharges present a danger, particularly to sensitive electronics

1.3 Coupling types

Surge voltages can reach a circuit in various ways. In reality, it is usually a case of an overlap between individual coupling types.

Galvanic coupling

Two circuits that are connected to each other in an electrically conductive way can directly and mutually influence each other. A change in the voltage or current in a circuit generates a corresponding reaction in another circuit.

Inductive coupling

A rapidly rising flow of current through a conductor generates a magnetic field, with quickly changing strengths around the conductor. If another conductor

is located in this magnetic field, then according to the induction principle, a voltage difference occurs here due to the change in the magnetic field strength.

Capacitive coupling

An electrical field occurs between two points with different potentials. The charge carriers of objects within this field are aligned according to the field direction and strength, in line with the physical principle of influence. As such, a potential difference also occurs within the object, in other words, a voltage difference.

1.4 Direction of action

Common mode voltage (asymmetrical voltage)

In the first instance, common mode surge voltages present a hazard to objects that are located between active potentials (phases and neutral conductors) and the ground potential.

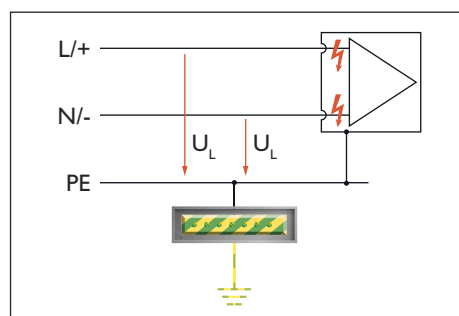

Fig. 4: Common mode voltage

Normal-mode voltage (symmetrical voltage, differential mode)

In the first instance, the symmetrical surge voltages present a hazard to objects that are located between two active potentials.

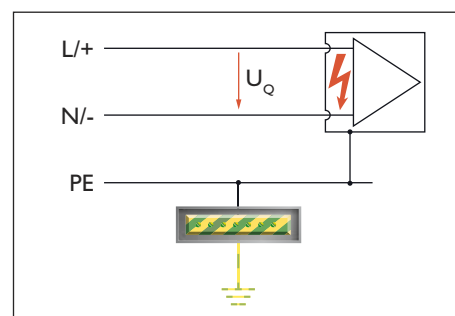

Fig. 5: Normal-mode voltage

1.5 Effects

The German Insurance Association (GDV) regularly publishes statistics, allowing conclusions to be drawn on the total losses resulting from various causes. Following fires and storms, lightning strikes and surge voltages cause the most damage. In 2012, their share of damage to all insured items totaled 18%. In other words, almost a fifth of insured damage can be traced back to a surge voltage.

Device failure or defects caused by surge voltages are more frequent than expected. According to statistics from the GDV, surge voltages are in fact the most frequent cause of damage. These figures only apply to damage that resulted in fire.

Fig. 6 shows that the proportion of damage caused by lightning and surge voltages in 2013 has dropped by 20% in comparison to the previous year. The financial payments by insurance providers, however, fell by just 10%. If the values from the comparable year of 2010 are taken as a basis, then a cost

increase of approximately 20% become apparent. Insurers consider one of the causes to be that ever more sensitive electronic devices are finding their way into households. On average, an individual strike or damage from a surge voltage amounted to €800 in 2013. This is the highest level since statistics began.

For non-private systems, however, the consequences of a failure are generally much more serious, such as downtimes or data loss. The failure of a device or a machine that is used in a professional environment often leads to costs that are many times higher than repairing the defective device.

For example, if a mobile communication mast fails, the cost for the operator can lie in the range of several euros per second. Calculated over the course of a day, this corresponds to damages of more than €100,000.

For this reason, a consistent surge protection concept is urgently required for industrial and business systems. It

is not just a case of having effective protection for fire and personnel, but also about excluding the possibility of large financial risk.

A further aspect that will underline the need for lightning and surge protection in the future is the increase of lightning strikes, as shown by statistics. Various studies have already shown that as part of global climate change, the frequency of storms is set to increase. This development is thereby not only limited to regions which have not displayed a high risk of strikes to date, but extends to all regions on Earth.

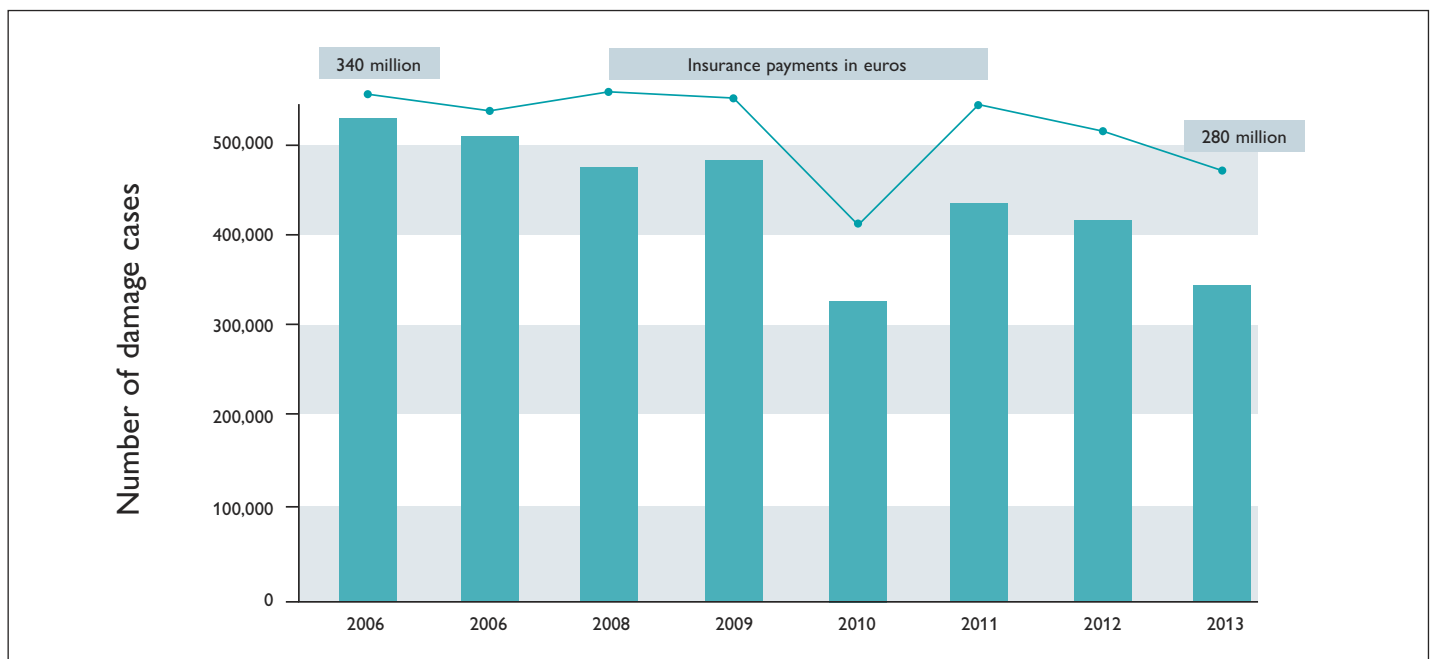

Fig. 6: Number of damage cases caused by lightning strikes and surge voltages and level of insurance payments

2 Surge protection: what should be noted?

Effective surge protection is not just simply installed. It has to be individually coordinated – to the system that is to be protected and the ambient conditions that are prevalent on site. For this reason, the design and concept must be consistent. This means many details must be taken into account, from considering the standards and stipulations right through to classification according to lightning protection zone.

2.1 This is how surge protection works

Surge protection should ensure that surge voltages cannot cause damage to installations, equipment or end devices.

As such, surge protective devices (SPDs) chiefly fulfil two tasks:

- Limit the surge voltage in terms of amplitude so that the dielectric strength of the device is not exceeded.
- Discharge the surge currents associated with surge voltages.

The way in which the surge protection works can be easily explained by means of the equipment's power supply diagram (Fig. 7).

As described in Section 1.4, a surge voltage can arise either between the active conductors as normal-mode voltage (Fig. 8) or between active conductors and the protective conductor or ground potential as common mode voltage (Fig. 9).

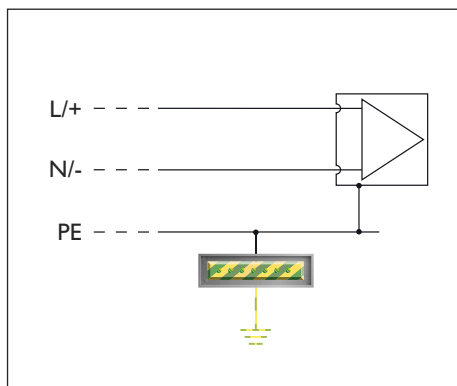

Fig. 7: Schematic power supply of a piece of equipment

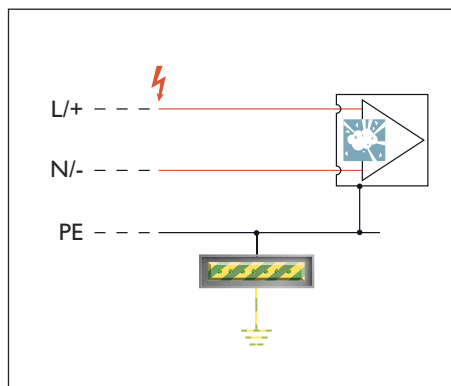

Fig. 8: Effects of a surge voltage as normal-mode voltage

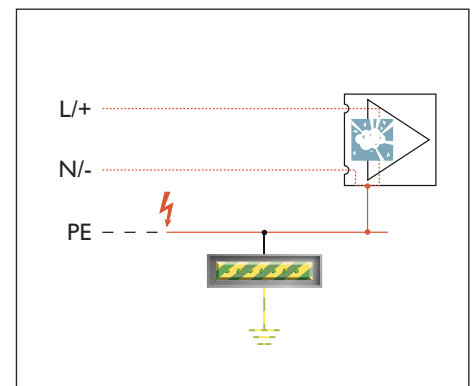

Fig. 9: Effects of a surge voltage as common mode voltage

With this in mind, surge protective devices are installed either in parallel to the equipment, between the active conductors themselves (Fig. 10) or between the active conductors and the protective conductor (Fig. 11).

A surge protective device functions in the same way as a switch that turns off the surge voltage for a brief time. By doing so, a sort of short circuit occurs; surge currents can flow to ground or to the supply network. The voltage difference is thereby restricted (Fig. 12 and 13). This short circuit of sorts only lasts for the duration of the surge voltage event, typically a few microseconds. The equipment to be protected is thereby safeguarded and continues to work unaffected.

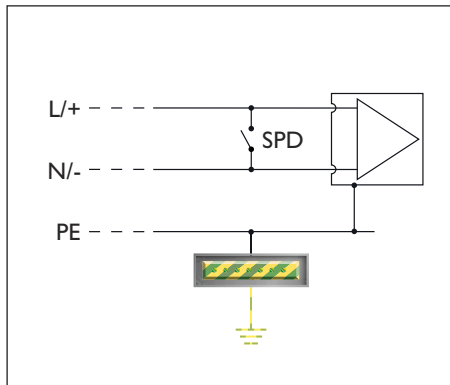

Fig. 10: SPD between the active conductors

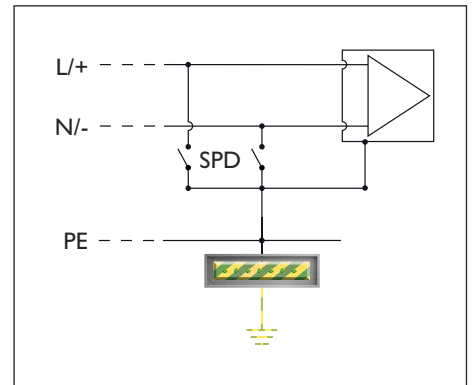

Fig. 11: SPD between active conductors and the protective conductor

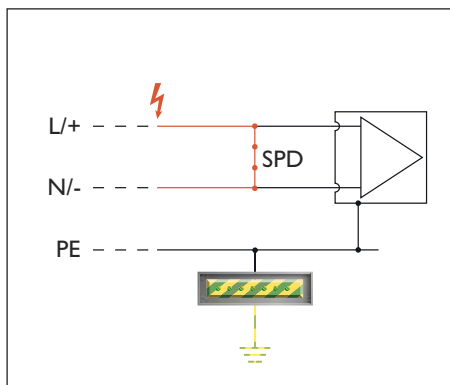

Fig. 12: SPD between the active conductors in the case of normal-mode voltage

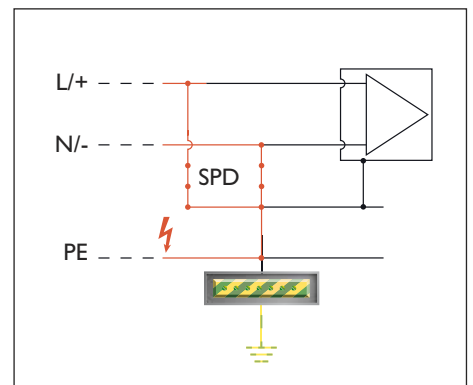

Fig. 13: SPD between active conductors and the protective conductor in the case of common mode voltage

2.2 Lightning and surge protection standards

National and international standards provide a guide to establishing a lightning and surge protection concept as well as the design of the individual protective devices. A distinction is made between the following protective measures:

- Protective measures against lightning strike events: lightning protection standard IEC 62305 [1] [2] [3] [4] deals with this. A key component of this is an extensive risk assessment regarding the requirement, scope, and cost-effectiveness of a protection concept.

- Protective measures against atmospheric influences or switching operations: IEC 60364-4-44 [5] deals with this. In comparison with IEC 62305, it is based on a shortened risk analysis and uses this as the basis for deriving corresponding measures. In addition to the standards mentioned, if applicable, other legal and country-specific stipulations are also to be considered.

2.2.1 Lightning protection according to IEC 62305

Part 1: Characteristics of lightning strikes

In Part 1 of this standard [1], the characteristic properties of lightning strikes, the likelihood of occurrence, and the potential for hazard are taken into account.

Part 2: Risk analysis

The risk analysis according to Part 2 of this standard [2] describes a process with which, first of all, the need for lightning protection for a physical system is analyzed. Various sources of damage, e.g., a direct lightning strike in the building, come into focus, as do the types of damage resulting from this:

- Impact on health or loss of life
- Loss of technical services for the public
- Loss of irreplaceable objects of cultural significance
- Financial losses

The financial benefits are determined as follows: how does the annual total

cost for a lightning protection system compare to the costs of potential damage without a protection system? The cost evaluation is based on the outgoings for the planning, assembly, and maintenance of the lightning protection system.

Parts 3 and 4: Planning aids and specifications

If the risk assessment determines that lightning protection is required and cost-effective, then the type and scope of the specific measures for protection can be planned based on Parts 3 [3] and 4 [4] of this standard. The lightning protection level determined by risk management is decisive for determining the type and scope of the measures.

For physical structures that require an extremely high level of safety, almost all strikes must be captured and conducted away safely. For systems where a higher residual risk is acceptable, strikes with lower amplitudes are not captured.

Fig. 14 shows the lowest peak value of strikes that can still be captured safely as well as the highest peak value of strikes

that can be conducted away safely depending on the lightning protection level. This is described by means of Lightning Protection Levels I to IV.

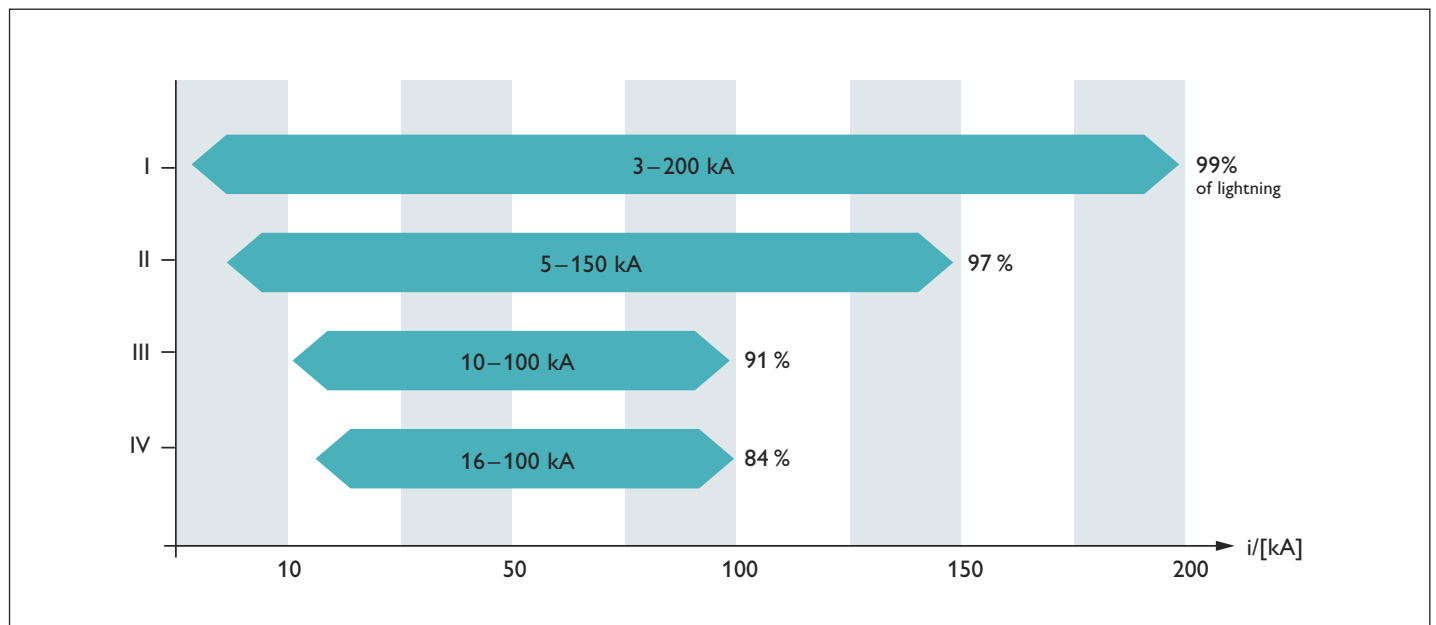

Fig. 14: Lightning Protection Levels

2.2.2 Surge protection according to IEC 60364-4-44

This standard [5] describes the conditions in which surge protective devices are to be used in low-voltage systems to protect the electrical installation against surge voltages. The area of application is thereby limited to surge voltages caused by atmospheric influences or as a consequence of switching procedures that are transmitted by the power supply system. Direct lightning strikes in a structural system are not considered, only strikes in or in the vicinity of supply lines.

Likewise, structural systems with an explosion risk as well as structural applications that could cause damage to the environment (e.g., petrochemical systems or nuclear power plants) are not included in the application of the standard. For these processes, lightning strike standard IEC 62305 is to be used exclusively.

Surge protective devices should be used if transient overvoltages could have effects on the following:

- Human lives, e.g., safety systems, hospitals
- Public and cultural institutions, e.g., loss of public services, IT centers, museums

- Industrial or business activities, e.g., hotels, banks, production systems, farms

In all other cases, a risk assessment must be carried out in line with the international standard.

2.3 Basic protective measures and equipment

In order to consistently protect a structural system from lightning strikes and surge voltages, various protective measures or equipment that are tailored to one another are required. A broad division can be made as follows:

- External lightning protection
- Internal lightning protection
- Grounding and equipotential bonding
- Coordinated SPD system

2.3.1 External lightning protection

External lightning protection (Fig. 15) aims to divert strikes which come near to the object to be protected and to transmit the lightning current from the point where it hits to ground. As such, no damage can be caused by means of thermal, magnetic or electrical effects. External lightning protection is systematic: it consists of the air-terminal, the arresters, and the grounding system.

Part 3 of standard IEC 62305 [3] is crucial when it comes to planning and erecting external lightning protection systems. Identifying and determining the

Lightning Protection Level is the basis for this. This is derived from the risk analysis. If there are no regulations or specifications for the external lightning protection, a minimum of Lightning Protection Level III is recommended.

The location of the interception units on the building also has to be decided.

There are three methods of doing so:

- Rolling sphere method
- Protective angle method
- Mesh method



Fig. 15 External lightning protection, on the outside of a private residence, for example

2.3.2 Internal lightning protection

The internal lightning protection system should prevent dangerous spark formation inside the system. Sparks can be caused by lightning current in the external lightning protection system or in other conductive parts of the structural system.

The internal lightning protection system consists of equipotential bonding and the electrical insulation of external lightning protection systems.

Lightning protection equipotential bonding is a combination of measures that prevent potential differences. They mainly connect the lightning protection system to metal installations, internal systems, as well as electrical and electronic systems within the system. This occurs by means of equipotential bonding lines, surge protective devices or isolating spark gaps.

To insulate the external lightning protection system, a minimum distance between electrical lines and metal installations must be kept, referred to as the separation distance.

2.3.3 Grounding and equipotential bonding

The grounding system aims to distribute and discharge the captured lightning current to ground. Here, the type of grounding system is more important than the grounding resistance. The lightning current is a very short pulse that behaves like a high-frequency current. Effective equipotential bonding is also important. Equipotential bonding connects all electrically conductive parts with each other via conductors – active conductors are protected by surge protective devices. By doing so, it protects against all types of couplings.

2.3.4 Coordinated SPD system

A coordinated SPD system is understood to be a multi-level system of surge protective devices that are coordinated with each other.

The following steps are recommended in order to achieve a high-performance SPD system.

- Divide the structural system into lightning protection zones

- Incorporate all lines that cross between different zones into the local equipotential bonding using suitable SPDs
- Coordinate different types of SPDs: the devices must address each other selectively in order to prevent individual components from overloading
- Use short supply lines for the parallel connection of SPDs between active conductors and the equipotential bonding
- Lay protected and unprotected lines separately
- Only ground equipment via the respective SPD (recommended)

2.4 Lightning protection zones

Deciding where to install surge protective devices within a structural system is based on the lightning protection zone concept explained in Part 4 of the lightning protection standard IEC 62305 [4].

It divides structural systems into lightning protection zones (LPZ), and does so from outside to inside with decreasing lightning protection levels. In external zones only resistant equipment can be used. However, in internal zones, sensitive equipment can also be used. The individual zones are characterized and named as follows:

LPZ 0_A

Unprotected area outside a building in which direct lightning strikes are a possibility. Direct coupling of lightning currents in lines, unattenuated magnetic field of the lightning strike.

LPZ 0_B

Area outside the building that is protected from direct lightning strikes by means of an air-terminal. Unattenuated magnetic field of the lightning strike, only induced surge currents on lines.

LPZ 1

Area inside the building which may still be subjected to high-energy surge voltages or surge currents and strong electromagnetic fields.

LPZ 2

Area inside a building which may still be subjected to surge voltages or surge currents and electromagnetic fields that have already been significantly weakened.

LPZ 3

Area inside the building which may only be subjected to extremely low or hardly any surge voltages or surge currents and very weak or non-existent electromagnetic fields.

All lines that cross between zones must use coordinated surge protective devices (Fig. 16). Their power values are based on the protection class to be achieved, which is determined according to legal specifications or by means of the risk analysis. When it comes to selecting surge protective devices, use the standard as a basis, assuming that 50% of the lightning current will be discharged to ground. The other 50% of the lightning current is directed to the electrical installation via the main equipotential bonding and from there must be conducted away from the SPD system.

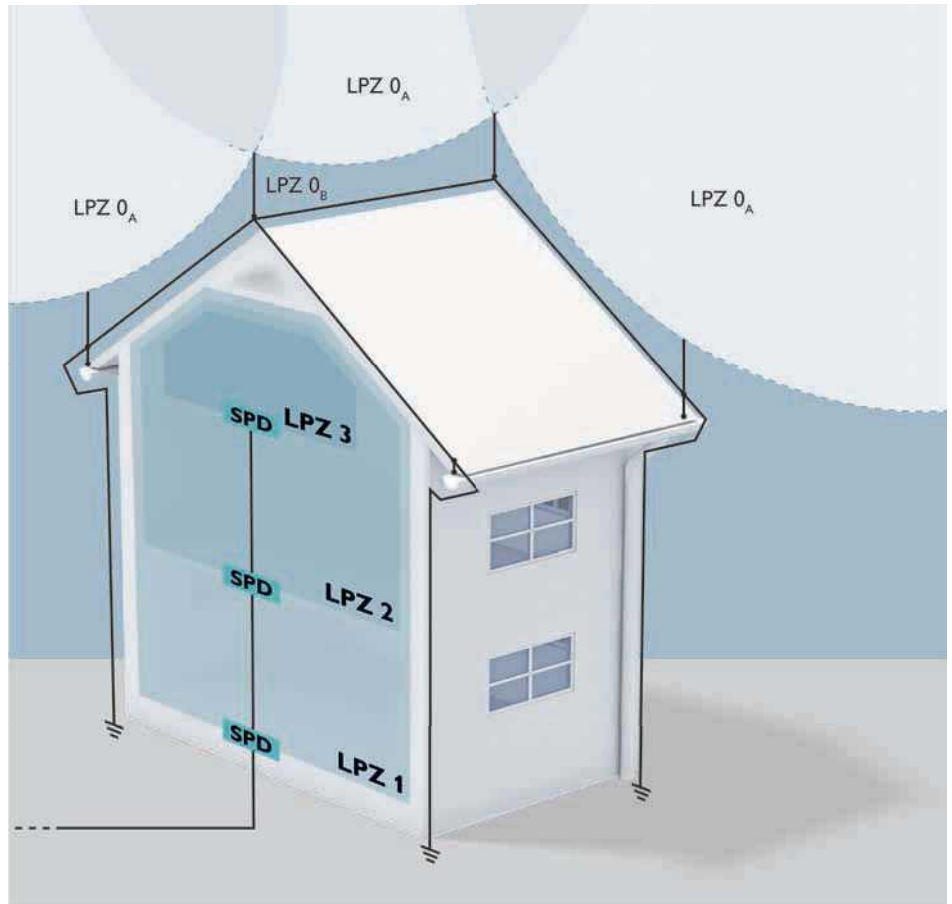

Fig. 16: Lightning protection zone concept

2.5 The protective circle principle

A clear depiction of the lightning protection zone concept is shown by the protective circle in Fig. 17. An imaginary circle should be drawn around the object to be protected. Surge protective devices should be installed at all points where cables intersect this circle. The area within the protective circle is therefore protected in such a way that conducted surge voltage couplings are prevented.

The protective circle must include all electrical and electronic transmission lines in the following areas:

- Power supply
- Measurement and control technology
- Information technology
- Transceiver systems



Fig. 17: Protective circle

3 Classification and testing of surge protective devices

Surge protective devices must provide defined protective functions and performance parameters in order to be suitable for use in corresponding protection concepts. As such, they are developed, tested, and classified according to their own international series of product standards. Yet even during use at a later stage, proper operation and therefore adherence to the protective function must be checked at regular intervals, as is also required of other safety-related components in electrical installations and electronic systems.

3.1 Requirements according to product standard IEC 61643

Surge protective devices/SPDs are generally classified according to performance values, depending on the protection class and location of use, and following product standard IEC 61643. It contains definitions of terms, general requirements, and testing procedures for surge protective devices. The standard distinguishes between:

- IEC 61643-11: Surge protective devices connected to low-voltage power systems – Requirements and test methods [6]
- IEC 61643-21: Surge protective devices connected to telecommunications and signaling networks – Performance requirements and testing methods [7]
- IEC 61643-31: Surge protective devices connected to low-voltage

power systems – Requirements and test methods for surge protective devices to be used in photovoltaic installations [8]

In future, this series will be extended by the following:

- IEC 61643-41: Surge protective devices connected to low-voltage DC systems – Requirements and test methods



Fig. 18: IEC 61643 – the product standard for surge protective devices

3.2 Key characteristics for surge protective devices

Nominal voltage (U_N)

The nominal value of the voltage of the current or signal circuit based on the use envisaged for the SPDs.

The nominal voltage stated for an SPD corresponds to the system voltage of the typical SPD installation site for a standard three-phase system, e.g., 230/400 V AC. Lower system voltages can also be protected by the SPD. In the event of higher system voltages, it must be decided on a case-to-case basis as to whether the SPD can be used and if there are restrictions to observe.

Nominal load current (I_L)

Maximum r.m.s. value of the nominal current, which allows a connected ohmic load to flow to one of the protected outputs of the SPD.

This maximum value is specified by the parts carrying operational current within the SPDs; these must be able to withstand the continuous thermal current load.

Short-circuit withstand capability (I_{SCCR})

Maximum uninfluenced short-circuit current of the electrical network, for which the SPD is rated in conjunction with the upstream overcurrent protective device.

The short-circuit withstand capability indicates up to which prospective short-circuit current the SPD can be used at the installation location. The corresponding tests to determine this value are carried out in connection with the upstream overcurrent protective device (or overcurrent protective device, OCPD). In the event that the special surge protective devices for photovoltaic systems correspond to the value I_{SCPV} , this is the maximum direct current short-circuit current of a system up to which the the SPD may be used.

Maximum continuous voltage (U_C)

Maximum r.m.s. value of the voltage that can continuously be applied to the mode of protection of the SPDs.

The maximum continuous voltage must be at least 10% higher than the value of the nominal voltage. In systems with greater voltage deviations, SPDs must be used where a greater difference is exhibited between U_C and U_N .

Voltage protection level (U_p)

Maximum voltage that can occur on the connection terminal blocks of the SPDs while loaded with a pulse of specific voltage steepness and load with a discharge surge current of specified amplitude and wave form.

This value characterizes the surge voltage protective effect of the SPDs. In the event of a surge voltage phenomenon within the performance parameters of the SPD, the voltage is safely limited to a maximum of this value at the protected connections of the SPD.

Pulse discharge current (I_{imp})

Peak value of the current flowing through the SPD with pulse shape (10/350 μ s).

The pulse shape (10/350 μ s) of a surge current is characteristic of the effects of a direct lightning strike. The value of the pulse discharge current is used for special SPD tests to demonstrate carrying capacity with regard to high-energy lightning currents. Depending on the Lightning Protection Level assigned to a lightning protection system, the SPDs must have minimum values that correspond to this value.

Nominal discharge current (I_n)

Peak value of the current flowing through the SPD with pulse shape (8/20 μ s).

The pulse shape (8/20 μ s) of a surge current is characteristic of the effects of an indirect lightning strike or switching operation. The value of the nominal discharge current is used for a variety of tests on an SPD, including those used to determine the voltage protection level. Depending on the Lightning Protection Level assigned to a lightning protection system, the SPDs must have minimum values that correspond to this value.

Off-load voltage (U_{OC})

Off-load voltage of the hybrid generator at the terminal points of the SPD.

A hybrid generator creates a combined surge; e.g., in off-load, it supplies a voltage pulse with a defined pulse shape, generally (1.2/50 μ s), and in a short circuit, a current pulse with a defined pulse shape, generally (8/20 μ s). The combined surge is characteristic of the effects of an induced surge voltage. Depending on the protection class assigned to a lightning protection system, the SPDs must have minimum values that correspond to this value.

Normative surge current pulses

The voltage-limiting function of the SPDs is tested using surge currents with a pulse shape of (8/20 μ s) (Fig. 19), i.e., with a rise time of 8 μ s and a decay time to half value of 20 μ s. This particularly dynamic pulse shape also provides information regarding the response behavior of the SPD. The voltage rise associated with this surge current is very

steep. Consequently, the voltage-limiting function of the SPD must be applied at very short notice.

SPDs that are designed to protect against direct lightning currents are additionally loaded with surge currents with a pulse shape of (10/350 μ s) (Fig. 20).

The maximum amplitude is based on the pulse discharge current specified by the

manufacturer. This pulse shape contains several times the electrical load in comparison to the (8/20 μ s) pulse shape, at the same amplitude. It therefore places a considerably higher load on the SPD in terms of energy.

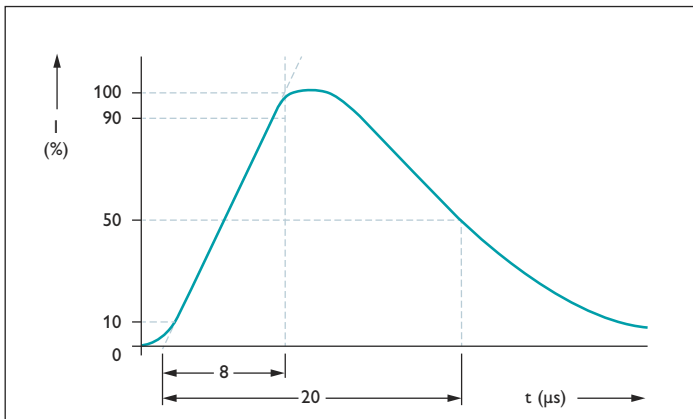

Fig. 19: Course of a (8/20 μ s) pulse

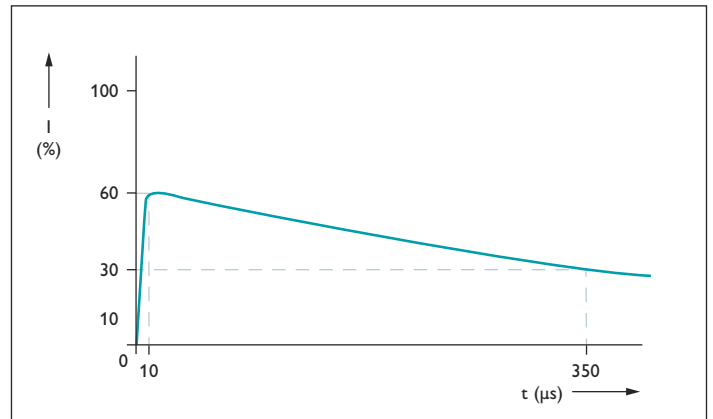

Fig. 20: Course of a (10/350 μ s) pulse

3.3 Maintenance and testing according to IEC 62305

To achieve high system availability, system operators must regularly inspect and maintain their electrical systems (Table 1). This is stipulated by legislators, supervisory authorities or professional associations based on the respective system type. Regular testing and maintenance of lightning protection

systems – internal and external lightning protection – is required as part of lightning protection standard IEC 62305-3 [3], also in Appendix E.7. Specialist knowledge is required in order to carry out professional testing of lightning protection systems. For this reason, this test must be carried out by

a lightning protection expert. Inspecting the SPDs is also part of this. The standard also demands that maintenance is properly documented. The three following points are particularly important to note:

Lightning Protection Level	Visual check (years)	Comprehensive testing (years)	Comprehensive testing in critical situations (years)
I and II	1	2	1
III and IV	2	4	1

Table 1: Testing intervals according to IEC 62305

- “Comprehensive testing in critical situations” relates to structural systems that contain sensitive systems or systems with a higher number of personnel.
- Explosion-protected, structural systems should undergo a visual check every 6 months. The electrical test of the installations should be carried out once a year.
- For systems with strict requirements in terms of safety technology, for example, the legislator can prescribe a comprehensive check. This can be necessary if there has been a lightning strike within a certain radius of the respective system.

3.3.1 Electrical test

At this point the question arises as to what exactly should be covered by a comprehensive test. A visual check alone often cannot reliably provide an idea of the functional efficiency of an SPD. An electrical test, however, can clearly show the performance capacity of the SPD.

When carrying out the electrical test of SPDs, the test voltage is selected in such a way as to make the SPD conductive. The measurement results are then compared to reference values and evaluated.

3.3.2 CHECKMASTER 2 test device

The CHECKMASTER 2 (Fig. 21) is a portable, robust, and safe to operate high-voltage testing device from Phoenix Contact for pluggable surge protective devices. It carries out an automatic, electrical test of pluggable SPDs.

Advantages

The intelligent test device with a modular design is equipped with an operating screen, a barcode scanner, and a programmable logic controller as well as a current-limiting, high-voltage power supply unit that can be controlled remotely. Thanks to the use of test adapters, the CHECKMASTER 2 can easily be adjusted to different surge protection devices. These test adapters are easy to swap without tools and there is no need to switch off the test device.

The CHECKMASTER 2 not only detects defective surge protective devices. It is also able to detect previously damaged surge protective devices, where the electrical parameters are at the limit of the defined tolerance range.

In order to also be able to check surge protective devices that will be developed in the future, software updates can be carried out via USB stick. These are available for component databases, the firmware, and operating languages.

The test record with test results, installation locations, and alphanumeric

values is stored in a failsafe manner and can be saved on a USB stick via a USB interface. It can be further processed using standard Office software (MS Word, MS Excel, etc.).

CHECKMASTER 2

The CHECKMASTER 2 enables convenient, fully-automated testing of pluggable surge protective devices. Surge protective devices that are defective or already exhibit damage are safely detected and can be preventatively replaced. All test results are documented in line with standards.



Fig. 21: CHECKMASTER 2 high-voltage test device

3.4 Pulse and high-current testing technology

Surge protective devices are more effective the more precisely they are tailored to the requirements and peculiarities of your area of application. The development of surge protective devices therefore demands laboratory simulation of the operating conditions – or more specifically, the electrical conditions, as well as the surge voltage events.

Realistic simulation of surge voltage events

For the test-based technical certification of high-performance SPDs of all types, high-performance low-voltage power supply systems must be simulated. This simulation is coupled to a surge current generator in order to create transient surge voltage events. It is only with a test arrangement of this type that the performance of the protective devices can be determined, as well as their interactions with different power supply systems. The IEC 61643-11 [6] standard describes a testing procedure in this context which is referred to as a work test. During this test, the surge

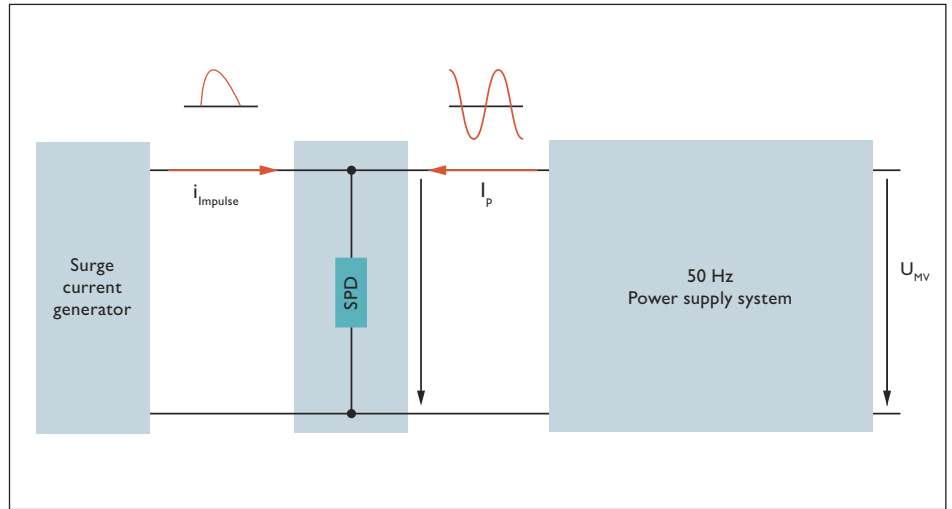

Fig. 23: Three-phase 50 Hz high-current testing system for simulating different low-voltage power supply systems

protective device is subjected to surge current pulses, while it is simultaneously connected to a specifically parameterized power supply system. The basic structure of such a testing system, which generally consists of surge current generator, surge protective device, and line-frequency power supply system, is depicted in Fig. 23.

Simulation of lightning surge currents

Surge current generators (Fig. 26) are key components of the high-current laboratory: they help to determine the discharge capacity, test components for external lightning protection, and also demonstrate the function of comprehensive surge voltage protection



Fig. 22: Resistance and inductance on the high- and low-voltage side of the testing transformer



Fig. 24: Testing stations of the high-current testing system



Fig. 25: Fully automated testing system for determining the overload and failure behavior of surge protective devices according to IEC 61643-11 [6]



Fig. 26: Lightning surge current generator

concepts. They simulate lightning surge currents with amplitudes of up to 100 kA and switching surge currents with amplitudes of 200 kA and above. The pulse shapes used in this context are specified as (10/350 μ s) pulses and are described in IEC 62305-1 [1].

Fully automated testing

The requirements placed on surge protective devices in line with IEC 61643-11 [6] demand tests (Fig. 25) that assess overload and failure behavior. A key test that simulates aging of the surge protective device as a result of increasing leakage currents is the test of thermal stability. This test can take several hours. Similar time-intensive and resource-intensive testing sequences are defined in IEC 61643-21 [7] for SPDs for use in signal transmission circuits.

Accreditation according to DIN EN ISO/IEC 17025

It is not only the technical equipment of the testing laboratory that counts: it is also the technical expertise of the employees, the effectiveness of the management system in terms

of quality assurance, as well as the independence and impartiality of the testing criteria. The essential requirements in terms of expertise for testing and calibration laboratories are described in DIN EN ISO/IEC 17025. The implementation and adherence to the standards may, for example, be checked and confirmed by the German Accreditation Body, DAkkS.

Laboratory operation at the highest level

- Every surge voltage event can be simulated. Phoenix Contact can simulate all low-voltage power supply systems with realistic characteristics – using its in-house, three-phase 50 Hz high-current testing system. It generates maximum short-circuit currents of up to 50,000 A. Furthermore, the testing parameters can be very finely graduated and adjusted – the ideal basis for developing tailor-made surge voltage protection systems.
- Testing results that are easy to reproduce, efficient testing operation. The Phoenix Contact laboratory is automated to a high degree and is therefore suitable for ongoing quality monitoring.
- Demonstrably the highest, independently verified quality. Phoenix Contact's pulse and high-current laboratory is accredited according to DIN EN ISO/IEC 17025.

4 Quality features

The quality and performance of surge protective devices are hard for a customer to assess. Correct functioning can only be tested in suitable laboratories. Besides the external appearance and haptics, only the technical data provided by the manufacturer can provide any guidance. Even more important is a reliable statement from the manufacturer regarding the performance of the SPD and the execution of the tests specified in the respective product standard from series IEC 61643.

4.1 CE declaration of conformity

An initial statement of quality is the CE declaration of conformity. It documents the fact that the product complies with the 2014/35/EU low-voltage directive issued by the European Union. For surge protective devices, fulfilling product standards from the EN 61643 series, which are based on IEC 61643, is a prerequisite.

Please note: the CE conformity assessment and declaration is issued by the manufacturer. It is therefore by no means a seal of approval by an independent institute or other attestation of an examination or

evaluation of the product by a third party. The CE mark only means that the manufacturer has confirmed adherence to the relevant regulations with regard to their product. If non-adherence to the relevant regulations or misuse of the CE marking is proven, legal steps can be initiated that may even result in prohibition of market launch under the European Union's supervision.



4.2 Independent product certifications

A true mark of quality is a product certification from an independent testing institute. These can also confirm fulfillment of the respective product standard. Furthermore, they can also document additional characteristics of the products, such as resistance to the effects of shocks and vibrations or safety requirements of specific domestic markets.

The regulatory requirements placed on SPDs sometimes require highly complex tests that only a few testing laboratories in the world are fully capable of carrying out. For ever more manufacturers and providers of SPDs, specifically in the lower pricing segment, the specifications regarding the performance of the devices are also to be taken into account. As such, the independent certification of SPDs

and therefore also the confirmation of performance specifications is becoming increasingly important.

KEMA, VDE, ÖVE, and more

This seal, issued by independent testing institutes, confirms that the current version of the respective product standard from the IEC 61643 series is fulfilled.

UL, CSA, EAC, and more

These approvals are examples of the requirements of specific domestic markets.

What's more, in their own standards, UL and CSA place safety requirements on the products for the North American markets or areas influenced by American markets. In contrast, EAC is rather an administrative approval of the products

for the European Economic Area. It is the same as the CE declaration of conformity and can also be extended on this basis.

GL, ATEX, IECEX, and more

These approvals verify the behavior of the products in specific ambient conditions.

GL certifies the products' resistance to external influences in the maritime environment as well as at sea, e.g., shocks, vibrations, humidity or salt concentration levels.

ATEX and IECEX in turn confirm the products' suitability for use in potentially explosive areas, such as those that frequently arise in the process industry.



Fig. 27: Product certifications by independent testing institutes

Independently verified quality

Phoenix Contact furnishes a large part of its surge protection product range with independent certifications. By doing so, compliance with standards and maximum product quality is documented for the user.

4.3 Expertise in surge protection

Application know-how

The further development of electrical systems and system technology always leads to new technologies, and as a consequence of this, to completely innovative technical solutions that place very specific requirements on surge protection. One example is the system technology that is used for renewable energies (photovoltaics and wind power). For this reason it is important to really understand the system to be protected and its environment, in order to develop tailor-made surge protective devices.

Research and development

The basis for ongoing development is intensive commitment to fundamental research and technological development. The following tasks are part of this:

- Determine the precise requirements placed on surge protective devices (protection objectives)
- Make new, appropriate materials available for applications

- Develop and master innovative basic technologies
- Structure development processes
- Develop new protection concepts as well as devices with tailor-made properties

Testing and certification

Testing systems that simulate real conditions are essential in order to develop surge protection concepts and devices. This also applies to technical laboratory trials.

Manufacturing and quality assurance

Manufacturing surge protective devices suitable for the market with the highest quality levels demands that many aspects relating to processes and procedures are taken into account during the development phase of these products. This requires early interlinking of product development activities with process and procedure development.

Measures to ensure quality are critical and should be carried out in series manufacturing as part of routine testing. For surge protective devices, destructive testing that records the product characteristics right to the performance limit and beyond can be useful. In this way, any possible deviations in manufacturing processes and consequently in product quality can be detected at an early stage.



Fig. 28: Practical application

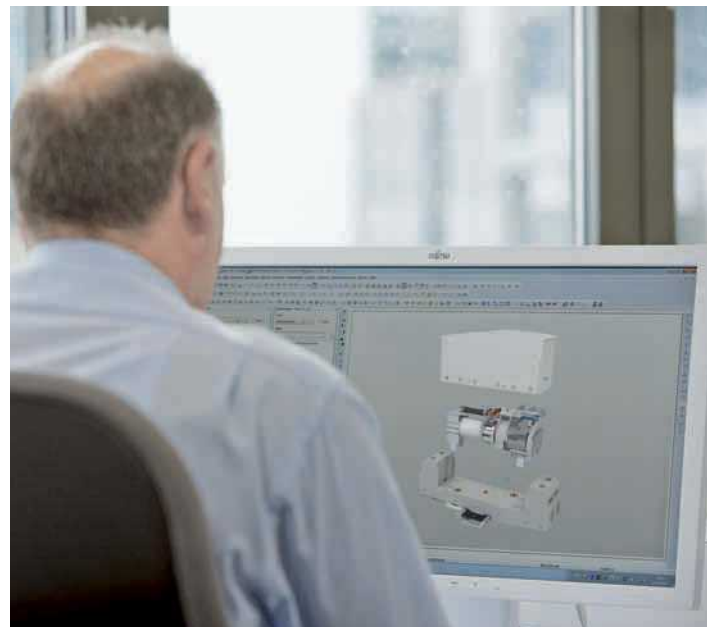

Fig. 29: Development shaped by research

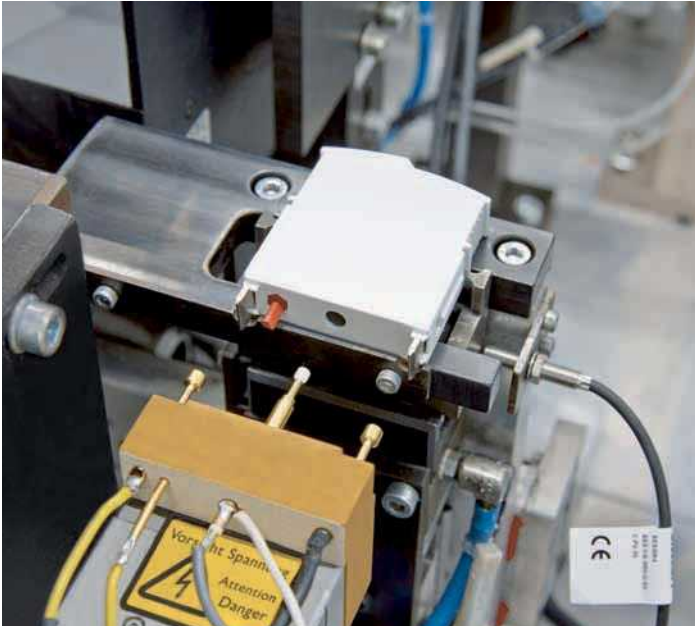

Fig. 30: Quality assurance in the production process



Fig. 31: Realistic testing conditions

A partner with experience and expertise

Benefit from many advantages with Phoenix Contact as your solution provider in the field of surge protection:

- Basic research and technological development in-house, which open up technologies and materials for surge protection in a targeted way and make them usable.
- Product development as part of a network, driven by collaborations with technology developers and universities as well as active involvement in relevant national and international prizes and working groups.
- Operation of an in-house pulse and high-current laboratory accredited by ISO/IEC 17025, which makes it possible to fully qualify surge protective devices in accordance with all current standards in the area of lightning and surge protection.
- Close interlinking of product, procedure, and process development makes it possible to implement all manufacturing aspects that are required in order to guarantee products at the highest quality level from the word go, when the product is created.
- Standardized quality tests that are carried out as automated routine testing alongside the manufacturing process or batch-based tests within the scope of a destructive sample test, ensuring products with the highest level of safety and quality.

5 The lightning monitoring system

Lightning strikes cause devastating damage to buildings and systems. They are a particular hazard for exposed structures such as offshore wind parks, radio masts, leisure facilities or high buildings. It is practically impossible for employees to continuously monitor exposed or large-scale systems, which means that damage is detected too late.

The LM-S lightning monitoring system can detect and analyze lightning strikes in real time. It provides information online about the intensity of the strike based on the typical lightning parameters. By consolidating the system operating parameters and the measuring data, the system provides a better basis for making decisions regarding control and maintenance.

5.1 Smart monitoring

Lightning strikes can cause devastating damage to buildings and systems. They can result in extensive destruction that can also have consequential damage.

The damage is dependent on the power and location of the strike. But the design of the lightning and surge protection concept has a bearing on the extent of the damage.

Systems that are particularly at risk of lightning strikes are those in exposed locations or with a large surface area, e.g., wind turbine generators, power plants, industrial operations covering a large area, and rail systems. In such systems, complete lightning protection is generally very difficult, or even impossible, to implement. Damage or

destruction to the system is often only monitored once consequential damage has occurred.

As a result, smart monitoring systems are used more and more. They constantly monitor the different functions in a system. They immediately report results to a central control unit. This helps the system to react immediately to errors and thereby to prevent consequential damage as well as long downtimes.



Fig. 32: The lightning monitoring system

5.2 Lightning current detection

The LM-S lightning monitoring system (Fig. 32) has the option of lightning current detection: if a strike hits the lightning interception rod, a magnetic field is created around the protective device that carries the lightning current. The LM-S uses the Faraday effect to measure this current. As such, the light is polarized in the measuring path of the sensor. The magnetic field resulting from the lightning strike makes the previously polarized light measurable (Fig. 33). The system transmits the light signal from the sensor via fiber optics to the evaluation unit. The characteristics of the lightning events – maximum amplitude, lightning current slope, specific energy, and charge – are detected and stored along with the date and time of the lightning strike.

If lightning strikes are measured in wind turbines or buildings, conclusions can be drawn at any time from the relation between the lightning parameters and the destruction associated with this. Furthermore, the evaluation enables conclusions to be drawn about the efficiency of the lightning protection system.

Lightning information systems are also used to collect information on lightning strikes for claims settlement. These systems can locate a lightning strike with a precision of up to 200 m. Whether and at what point the lightning strikes a building or system can only be determined with a lightning monitoring system – such as the LM-S.

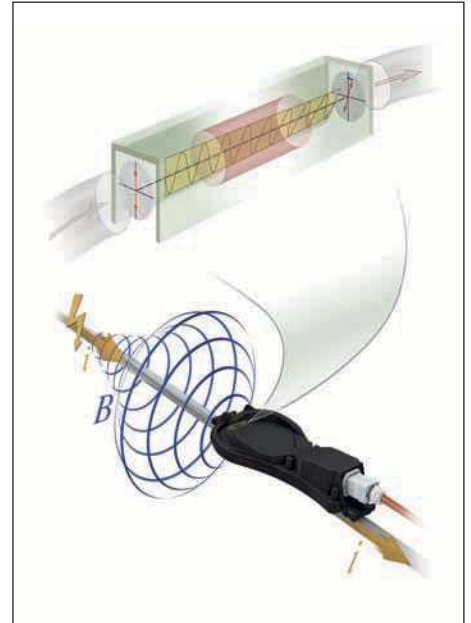

Fig. 33: Operating principle, Faraday effect



LM-S lightning monitoring system

The lightning monitoring system detects lightning strikes in the lightning protection system of a building or system. All measured data can be accessed remotely via various interfaces such as the integrated web interface or Modbus. The measured variables of the pulse current are:

- Amplitude I_{peak}
- Gradient di/dt
- Load Q
- Specific energy W/R



Fig. 34: Burj Khalifa, LM-S application

6 Fields of application

The IEC 61643 product standard divides applications where surge protective devices are used into low-voltage systems, telecommunications and signal processing networks, as well as photovoltaic installations. In general, all areas have very different individual system prerequisites. Correspondingly, all the solutions or steps involved can vary greatly. It is worth examining these applications in closer detail.

6.1 Protecting AC systems

6.1.1 SPD types and technologies

The lightning protection zone concept provides coordinated surge protective devices for all lines that cross between zones. Their power values are based on the protection class to be achieved.

Depending on the zone transition, different types are therefore required (refer to Table 2). The requirements for individual SPD types are defined in the product standard for surge protective devices, IEC 61643-11 [6].

A multi-level protection concept can be derived from this (Fig. 35).

Zone transition	SPD type	Designation
LPZ 0 _A → LPZ 1	Type 1	Lightning current arrester
LPZ 0 _B → LPZ 1	Type 2	Surge protective device
LPZ 1 → LPZ 2	Type 2	Surge protective device
LPZ 2 → LPZ 3	Type 3	Device protection

Table 2: Lightning protection zone transition and corresponding SPD type

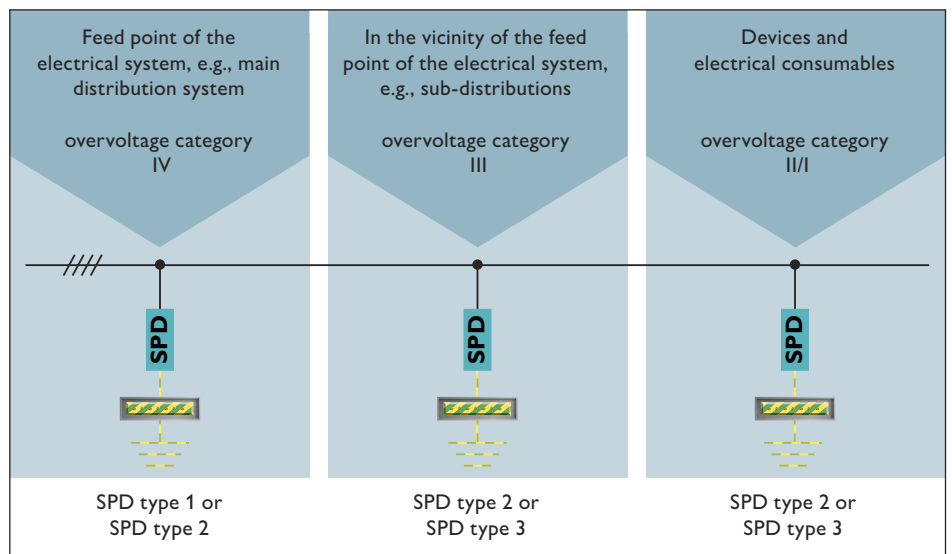

Fig. 35: Multi-level protection concept

The multi-level functionality limits the lightning protection level from zone to zone. The amplitudes and specific energies of the surge voltages or surge currents to be expected gradually decrease. The voltage value to which the individual SPDs must limit the surge voltages also decreases. This is achieved by correspondingly low voltage protection levels: their upper limits are based on the dielectric strength of the equipment to be protected in the immediate vicinity. The dielectric strength is specified according to IEC 60664-1 [9] in the overvoltage categories I to IV (Table 3).

6.1.2 Type 1: lightning current arrester

Type 1 surge protective devices must fulfil the highest requirements in terms of amplitude and specific energy from surge voltages or surge currents, as they are supposed to protect from direct lightning strikes. In the typical installation environment of the main distribution, the demand placed on the short-circuit withstand capability is often very high. In order to be able to meet these requirements, powerful technology is required, e.g., spark gap technology.

Spark gap technology

The operating principle of a spark gap is initially very simple: two electrodes are placed at a specific distance from each other and create an insulating state (Fig. 36). If there is a voltage present between the two electrodes that causes the dielectric strength of the air (approx. 3 kV/mm) in this space to exceed the surge voltage, then an electric arc is formed. In comparison to the insulating state with an impedance in the giga-ohm range, the impedance of the electric arc is extremely low and so, therefore, is the voltage drop across the spark gap.

This characteristic is ideal for discharging lightning currents: the lower the residual voltage of the spark gap, the

Nominal voltage of the power supply system (mains) according to IEC 60038		Conductor-neutral conductor voltage derived from the total nominal AC voltage or nominal DC voltage	Rated surge voltage			
Three-phase	Single-phase		Overvoltage category			
V	V	V	I	II	III	IV
		50	330	500	800	1500
		100	500	800	1500	2500
	120 – 240	150	800	1500	2500	4000
230/400 277/480		300	1500	2500	4000	6000
400/690		600	2500	4000	6000	8000
1000		1000	4000	6000	8000	12,000

Table 3: Overvoltage categories based on the nominal voltage

lower the energy input to be managed. With regard to the abrupt change of impedance, and therefore also the voltage difference across the spark gap, the non-linear characteristic is referred to as voltage-switching. A significant advantage that arises from the low residual voltage is the low load on the equipment to be protected as a result of voltages above the specified nominal voltage or maximum continuous voltage. For the comparatively long duration of lightning currents, the residual voltage of a spark gap is very low, in the range of the maximum continuous voltage of the device to be protected. Type 1 SPDs with voltage-limiting components are often several hundred volts over this – a significantly greater load for the protected equipment.

Modern spark gaps are generally encapsulated in robust, enclosed steel housings, so that during the discharge process, no ionized gases generated by the electric arc can escape into the environment. Furthermore, spark gaps are often triggered:

They have additional wiring to support the through-ignition of the spark gap. This limits the voltage protection level to a very low level – significantly lower than the voltage that results based on

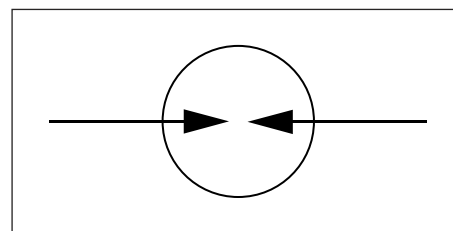

Fig. 36: Equivalent circuit of an enclosed spark gap

the dielectric strength of the air alone. Even if the installation environment of type 1 SPDs does not generally require it, the voltage protection level of modern, triggered spark gaps is often at the level of the lowest overvoltage category I (based on the nominal voltage of the system).

Sequential current extinguishing capacity

A special characteristic for spark gaps is the sequential current extinguishing capacity, I_{fi} . If a spark gap is ignited by means of a surge voltage, it represents a kind of short circuit that drives the current for the connected mains network. The spark gap must therefore be in the position to interrupt the mains current of its own accord, after the discharge process, without triggering the upstream overcurrent protective device. The sequential current extinguishing capacity indicates up to which prospective short-circuit current this is guaranteed at the installation location. Modern spark gaps must be able to do two things:

- Discharge large amounts of energy from brief lightning currents
- Independently eliminate sequential currents from powerful supply networks

In the case of lightning currents, in the best case, the impedance of the spark gap is very low, in order to keep the

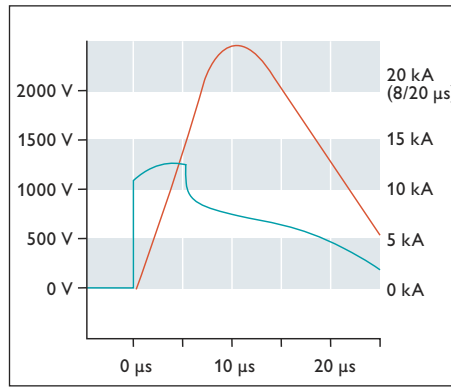

Fig. 37: Typical residual voltage curve of a triggered spark gap when loaded with a (8/20 μ s) pulse

energy input as low as possible and increase the robustness. In the case of sequential currents, however, the impedance must be as high as possible in order to ensure fast elimination.

In order to withstand high lightning current amplitudes of up to 50 kA on supply networks with possible short-circuit currents up to 100 kA, today's spark gaps are therefore often complex constructions and consist of many individual functional parts (Fig. 38).

Spark gap technology without line follow current

For maximum system availability, limiting the line follow currents is essential:

- Upstream overcurrent protective devices do not trip
- The installation is not loaded by high current flows
- The service life of the spark gap is increased

For the first time, Phoenix Contact has been able to develop and offer a spark gap on the market that is completely free of line follow currents, featuring Safe Energy Control technology (refer to 6.1.10).

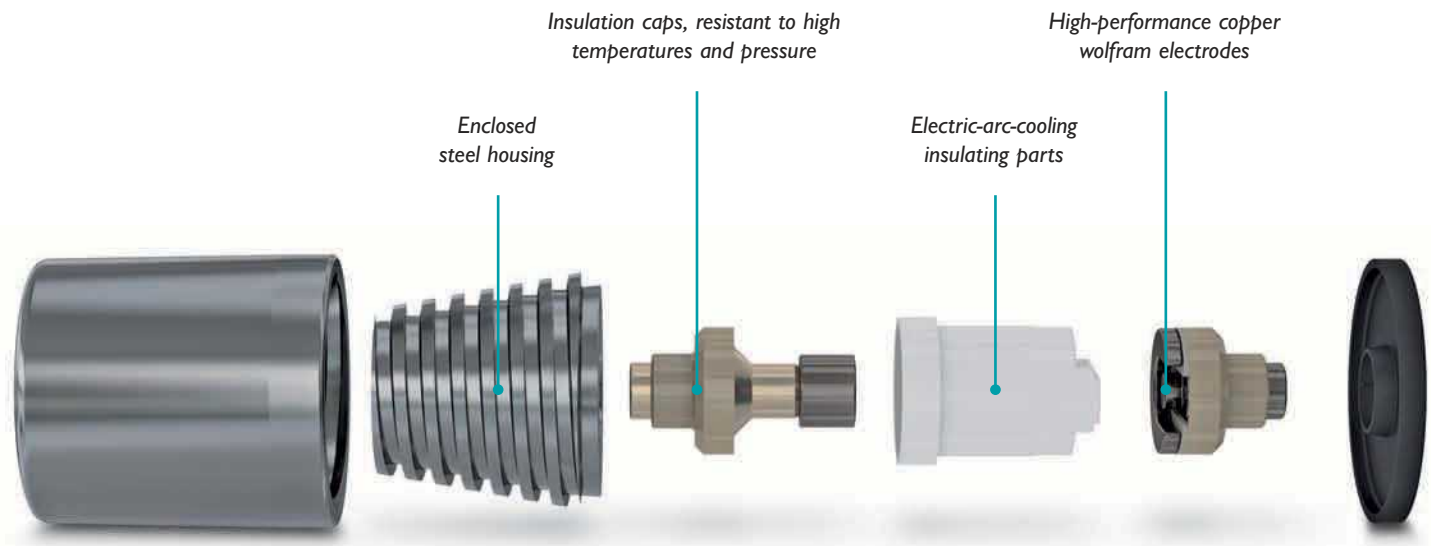

Fig. 38: Individual components of a modern, enclosed spark gap

6.1.3 Type 2: surge protective device

Type 2 surge protective devices are generally installed in sub-distributions or machine control cabinets. These SPDs must be able to discharge induced surge voltages from indirect lightning strikes or switching operations but not handle direct lightning strikes. As such, the energy input is significantly reduced. In any case, induced surge voltages caused by switching operations are often very dynamic. Here, a discharge technology with fast response behavior stands up to the test, e.g., varistor technology.

varistors as type 1 SPDs for Lightning Protection Level I. Despite this, this concept has serious shortcomings: if the characteristics of the varistors connected in parallel do not match precisely, a requirement that is very hard to meet, the individual paths are placed under differing loads during the procedure. Correspondingly, they age very differently. Over time, the uneven loads become ever greater. This finally leads to varistor overload.

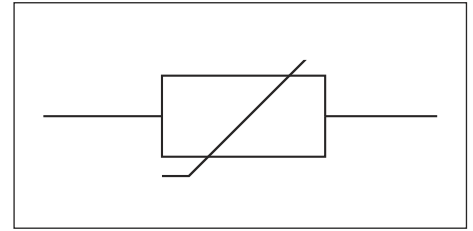

Fig. 39: Equivalent circuit diagram of a varistor

Varistor technology

Varistors (variable resistor or metal oxide varistor, MOV) (Fig. 39) are semiconductor components made from metal oxide ceramics. They exhibit a non-linear current-voltage characteristic curve (Fig. 40). In low voltage ranges, the impedance of a varistor is very high, however in higher voltage ranges the impedance drops away rapidly, so that very high currents can be discharged without any problems.

For this reason, the characteristics of varistors are referred to as voltage-limiting. With a typical response time in the lower nanosecond range, varistors are very well suited even to limiting particularly dynamic surge voltage phenomena.

Varistors that carry lightning current

High-performance varistor ceramics can even exhibit a pulse discharge capacity of up to 12.5 kA (10/350 μ s), which means that they are also suitable as a type 1 SPD for environments with low protection levels.

For a higher pulse discharge capacity of 25 kA to 50 kA (10/350 μ s), generally, multiple varistors must be used in a parallel connection. Surge protection manufacturers who have no spark gap technology therefore often use

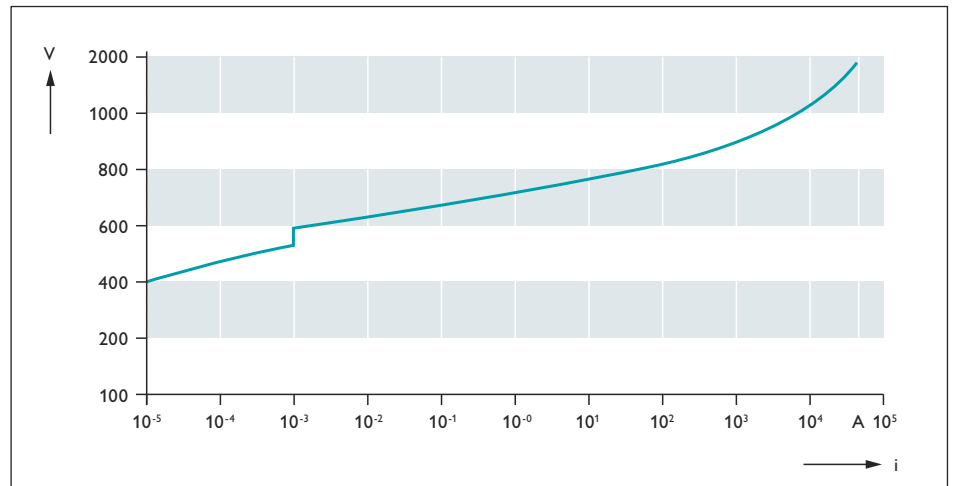

Fig. 40: Voltage-current characteristic curve of a varistor with 320 V AC rated voltage

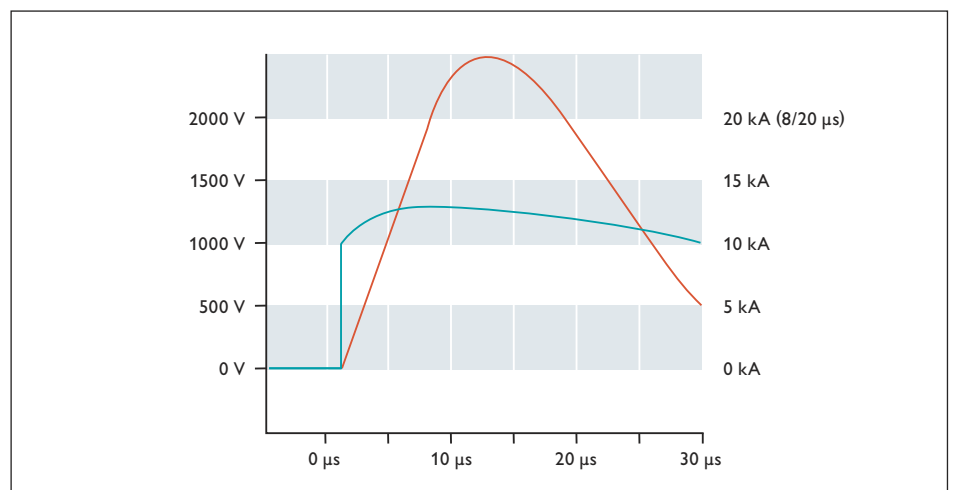

Fig. 41: Residual voltage of a varistor with 350 V AC rated voltage under a load of 25 kA (8/20 μ s)

6.1.4 Type 3: device protection

Type 3 surge protective devices are generally installed right in front of the terminal device to be protected. Due to differing installation environments, type 3 SPDs are available in a very wide range of designs. For example: in addition to standard DIN rail mounting, there are devices for installation in sockets or for direct mounting on a PCB of the end device.

Technologically speaking, type 3 SPDs are most similar to type 2, which are based on varistors, but the requirements in terms of nominal discharge capacity in comparison to type 2 are even lower.

Often it is sensible to link the protection of the power supply to the protection of other interfaces in the terminal device, such as data communication lines. There are combined devices for this purpose. They take on the surge protection for all corresponding (supply) lines.

6.1.5 Coordinating different SPD types

The lightning protection zone concept provides coordinated surge protective devices for all lines that cross between zones. Their power values are based on the protection class to be achieved.

Depending on the zone transition, different types are therefore required (refer to Table 2). The requirements for individual SPD types are defined in the product standard for surge protective devices, IEC 61643-11 [6].

A multi-level protection concept can be derived from this (Fig. 42).

Starting from the internal protection zones, a type 3 SPD and an upstream type 2 SPD are to be coordinated. It must be ensured that type 3 SPDs are not overloaded in terms of energy. Since surge voltages of a lower amplitude are expected in this area of the protection zone concept, selective addressing is already guaranteed by a U_c of the type 3 SPD, which is greater than or equivalent to the type 2 SPD.

In the direction of the external protection zones, the coordination between type 2 SPDs and upstream type 1 SPDs must once again be ensured. As the possibility of direct lightning strikes or partial lightning strikes must be considered here, which can only be borne by type 1 SPDs, selective addressing of the SPDs is particularly important otherwise the type 2 SPDs could be overloaded.

As the technologies used for type 1 SPDs are very different, there are no general conditions for coordination. Type 1 SPDs based on spark gaps provide a clear advantage in this area. Their comparatively low residual voltage of just a few hundred volts throughout most of the duration of the lightning current ensures the current flow is almost completely transitioned.

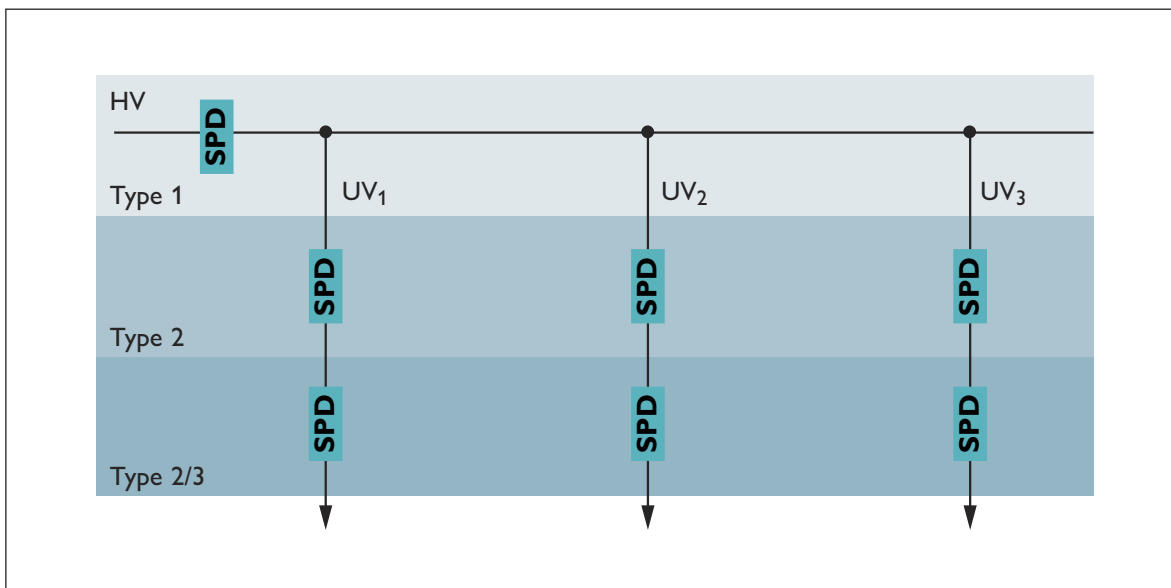

Fig. 42: Multi-level protection concept with a range of consecutive SPD types

6.1.6 Grid systems according to IEC 60364

The design of a surge protection concept for AC systems depends, among other things, on the existing grid system. These systems can vary depending on the design of the grounding of the transformer providing the supply, the consumer system, and their connection to one another.

The directive for erecting low-voltage power supply systems, IEC 60364-1 [10] lists the following system configurations:

TN-S system

In this grid system, one point – usually the neutral point – of the transformer supplying the energy is usually directly grounded. The neutral conductor (N) and protective conductor (PE) are routed to the consumer system in separate conductors. A three-phase power supply consists of five conductors: L1, L2, L3, N, and PE (Fig. 43).

TN-C system

In this grid system, the neutral point of the transformer supplying the energy is directly grounded. The neutral conductor and protective conductor are routed to the consumer system in one conductor (PEN). A three-phase power supply consists of four conductors: L1, L2, L3, and PEN (Fig. 44).

TT system

In this grid system, the grounded point of the transformer is routed to the system solely as a neutral conductor. The parts of the electrical system are connected to a local grounding system that is separated from the grounded point of the transformer. The neutral conductor and the local protective conductor are routed to the consumer system in separate conductors. A three-phase power supply consists of five conductors: L1, L2, L3, N, and local PE (Fig. 45).

IT system

In this grid system, the neutral point of the transformer supplying the energy is not grounded, or only grounded via a high impedance. The parts of the electrical system are connected to a local grounding system that is separated from the grounded point of the transformer. If a neutral conductor is also routed from the neutral point of the transformer supplying the energy, this is routed separately from the local protective conductor. A three-phase power supply consists of four or five conductors: L1, L2, L3, if appropriate, N, and local PE (Fig. 46).

One peculiarity of the IT system is that an insulation fault to ground may occur for a limited period of time. The ground fault in the phase must merely be detected by insulation monitoring and reported, so that it can be promptly rectified. Only in the event of a second ground fault would this lead to a short circuit between two phases and the relevant surge protection equipment would trip. Surge protective devices for use in IT systems must therefore be able to withstand the phase-to-phase voltage of the system as well as the tolerance. This is ensured by the normative requirement that only SPDs with a maximum continuous voltage of at least the phase-to-phase voltage plus tolerance may be used between the phase and PE in IT systems.

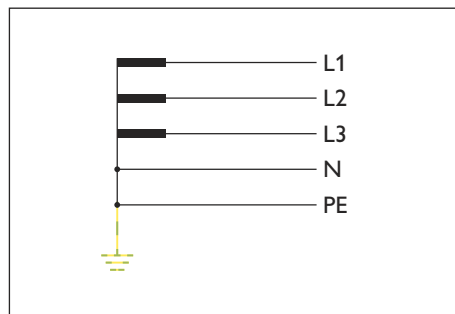

Fig. 43: TN-S system

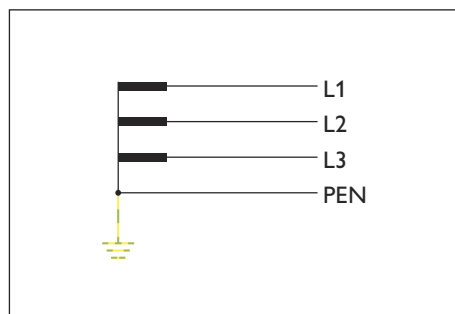

Fig. 44: TN-C system

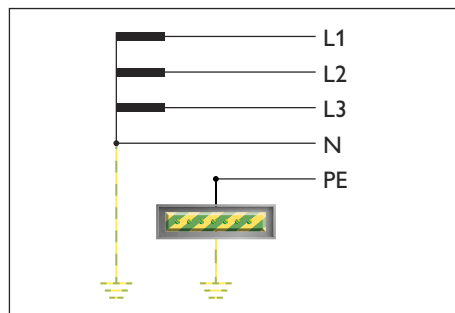

Fig. 45: TT system

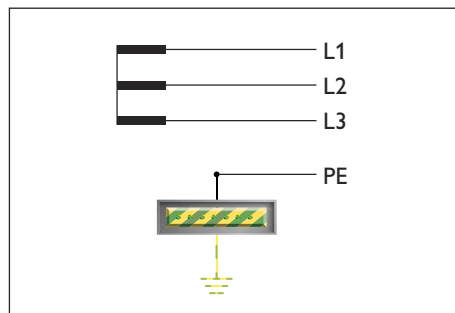

Fig. 46: IT system

6.1.7 American grid systems

Other grid systems are used, especially in the Northern and Central American regions. The most important are:

- Wye system
- Delta system
- Split-phase system

Wye system

These systems correspond to the TN systems; the neutral point of the supplying transformer is directly grounded and from there, the protective conductor (grounding conductor, GND) is routed to the consumer system.

Insulated wye systems do also exist, but there are comparably few. A possible neutral conductor is generally first of all tapped within the consumer system. This then corresponds to a TN-C-S system. A three-phase power supply consists of four or five conductors: L1, L2, L3, if appropriate, N, and GND (Fig. 47).

Delta system

These systems have no direct equivalent according to IEC. Grounding either takes place via one of the phases (corner-grounded) or via a center tap between two phases (high-leg). The GND is routed from the respective grounding point to the consumer system. Insulated delta systems do also exist, but there are comparably few.

The neutral conductor is, if required, also usually tapped within the consumer

system first of all. A three-phase power supply consists of four or five conductors: L1, L2, L3, if appropriate, N, and GND (Fig. 48).

Split-phase system

This widely used two-phase system is grounded by means of a center tap between the two phases and a neutral conductor is routed from there. A two-phase power supply consists of four conductors: L1, L2, N, and GND (Fig. 49).

6.1.8 Connection scheme

Surge protective devices are part of the equipotential bonding of a structural system. In the event of a surge voltage, they connect the active conductor in electrical installations with the grounding.

Depending on the grid system of the consumer system, different SPDs can be used. They are combined in various connection schemes (CT), to establish this connection. In the installation directive for surge protection, IEC 60364-5-53 [11], the following types are specified:

- CT1 connection scheme: a combination of SPDs that have a mode of protection between each active conductor (outer conductor and neutral conductor, if present) and PE conductor. This connection scheme is often designated as a x+0 circuit, whereby x represents the

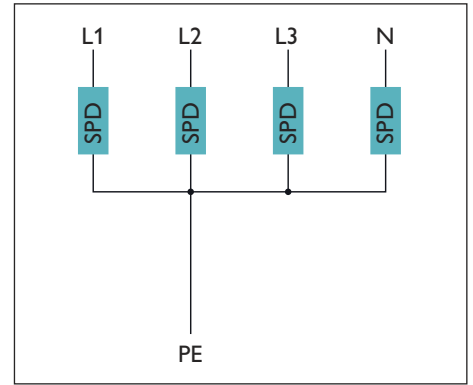

Fig. 50: CT1 connection scheme or 4+0 circuit

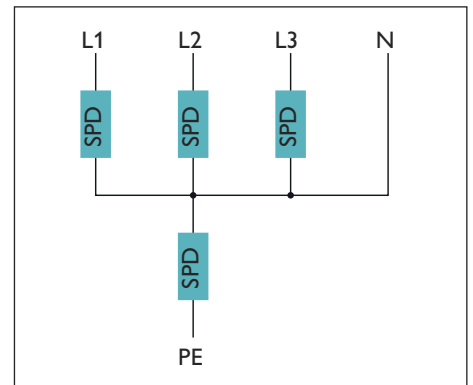

Fig. 51: CT2 connection scheme or 3+1 circuit

- number of active conductors (Fig. 50).
- CT2 connection scheme: a combination of SPDs that have a mode of protection between each outer conductor and neutral conductor and a mode of protection between the neutral conductor and the PE conductor. This connection

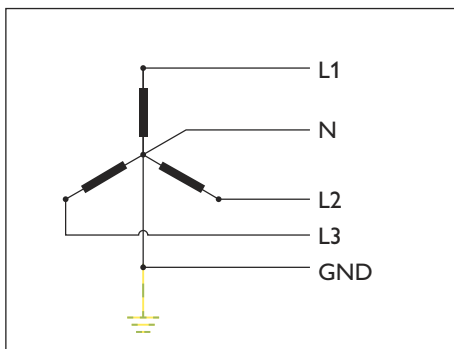

Fig. 47: Wye system

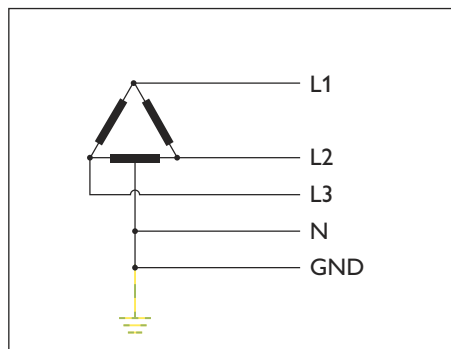

Fig. 48: High-leg and corner-grounded delta system

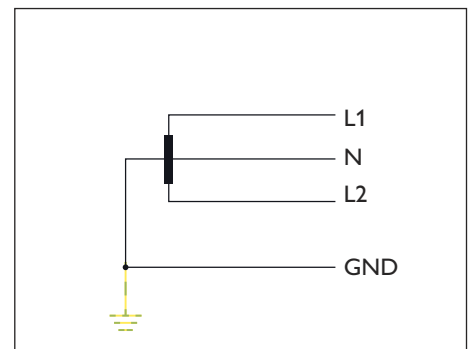

Fig. 49: Split-phase system

scheme is often designated as a x+1 circuit, whereby x represents the number of outer conductors (Fig. 51). The possible uses of this connection scheme in the individual grid systems are listed in Table 4.

6.1.9 Connection and overcurrent protection of SPDs

If transient overvoltages occur, an inductive voltage drop can result on the electrical conductors. This additional voltage drop in the connecting cables can weaken the protective effect, particularly when connecting surge protection in parallel to the equipment to be protected. With this in mind, the SPD connecting cables are always laid as short as possible with the largest possible bending radii.

SPDs can essentially be connected in two different ways:

- Branch wiring (stub wiring), refer to Fig. 52
- V-wiring (V-shaped wiring), refer to Fig. 53

In both cases, the total of the cable lengths a, b, and c, must not exceed 0.5 m. In the case of the V-wiring, this is particularly easy to ensure, as here only length c is of relevance. As such, even the overall protection level (consisting of the voltage protection level of the SPDs and voltage drop over the connecting cables) can be minimized as much as possible.

In the case of branch wiring, the SPD can or must be protected depending on the nominal value of the F1 upstream overcurrent protective device, with a second additional overcurrent protective device, F2, with a lower nominal value. This wiring enables use in systems with nominal currents of any strength, provided the prospective short-circuit current on the SPD installation location does not exceed its short-circuit withstand capability.

The V-wiring, however, can only be used up to a nominal value of the upstream overcurrent protective device

CT2 connection scheme

Phoenix Contact mainly provides SPDs with the CT2 connection scheme for TN and TT systems. The advantages of this connection type are:

- Can be used universally in all countries worldwide
- Lower voltage protection level between outer and neutral conductor
- No leakage current to the protective conductor due to the use of spark gaps between the neutral and protective conductor

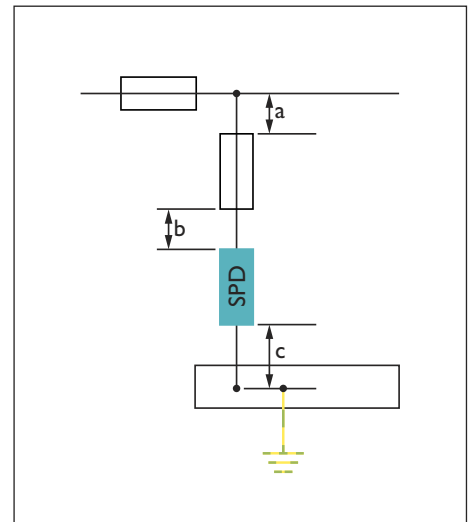

Fig. 52: Branch wiring

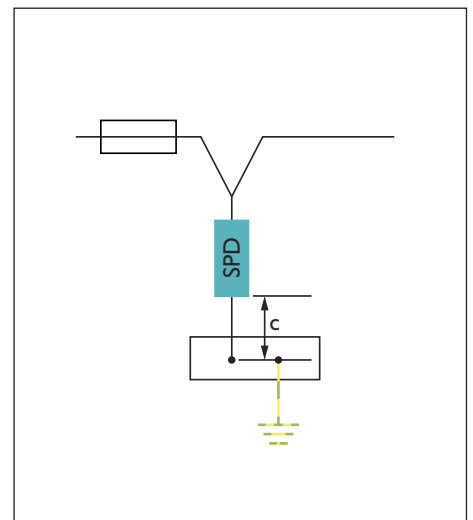

Fig. 53: V-wiring

Grid system at the SPD installation location	Connection scheme	
	CT1	CT2
TN system	✓	✓
TT system	Only downstream of a residual current protective device	✓
IT system with routed neutral conductor	✓	✓
IT system without routed neutral conductor	✓	NA

Table 4: Connection schemes and grid systems

F1 or a nominal current of the system that does not exceed the continuous current capacity of the connecting cables and the connection terminal blocks of the SPD.

As part of the electrical installation, corresponding legal or regulatory requirements are to be fulfilled for the connection and overcurrent protection of surge protective devices that principally aim to ensure the operational reliability of the system. Furthermore, for correct functioning of the surge protection, specific conditions are to be taken into account with regard to connection and fuse protection.

The requirements are based on various parts of IEC 60364 for creating low-voltage systems: on the one hand, Part 5, Section 53, Main Section 534 [11], regarding the selection and setup of surge protective devices, and on the other, Part 4, Section 43 [12], regarding protective measures against overcurrent, as well as the product standard for surge protective devices, IEC 61643-11 [6].

Connection cross sections

If these requirements are combined, this results in the following conditions for dimensioning the connecting cables of SPDs (based on PVC-insulated copper cables):

- The minimum cross sections for the SPD connecting cables first of all result from the requirements for installing surge protective devices, depending on the active conductor connection or the main grounding busbar/the protective conductor (PE(N)) as well as the type of the SPD:
 - Connection cross section of the active conductor for type 1 SPDs: min. 6 mm²
 - Connection cross section of the active conductor for type 2 SPDs: min. 2.5 mm²
 - Connection cross section of the main grounding busbar or the

protective conductor for type 1 SPDs: min. 16 mm²

- Connection cross section of the main grounding busbar or the protective conductor for type 2 SPDs: min. 6 mm²
- Over a specific nominal value of the upstream overcurrent protection, the minimum cross section is determined by the connecting cables' need for short-circuit withstand capability
- If the SPD connecting cables carry operating current, then the continuous current load can be used to determine the minimum cross section as of a certain current value

Overcurrent protection

When designing the overcurrent protection of SPDs, the various elements must first be prioritized:

- Priority of the system supply: Branch wiring with separate F2 overcurrent protective device in the branch
- Priority of the system surge protection: V-wiring or branch wiring without separate F2 overcurrent protective device

In the first case, the separate F2 overcurrent protection equipment ensures that in the event of the failure of the SPD (e.g., a short circuit), the F1 upstream overcurrent protective device does not trigger and that the supply to the equipment to be protected is not interrupted. In this case, however, the equipment is no longer protected from subsequent overvoltage events.

In the second case, the F1 upstream overcurrent protective device takes on the overcurrent protection in the event that the SPD fails. The failure of the supply is hereby accepted, so that no damage can be caused by subsequent overvoltage events.

When dimensioning the overcurrent protection, the following points should be kept in mind:

- Selectivity of the respective overcurrent protective device to

upstream overcurrent protective devices.

- The final overcurrent protective device before the SPD must not exceed the maximum nominal value of the upstream overcurrent protective device as specified by the SPD manufacturer.
- The upstream overcurrent protective device should, as far as possible, be able to bear the required amplitudes of lightning and surge currents, depending on the Lightning Protection Level. In particular with regard to high-energy lightning currents, under-dimensioned fuses can pose a risk, as they can be destroyed in a very short time due to high-energy inputs.

Adhering to the selectivity is therefore the top priority. In the simple case that the two overcurrent protective devices to be taken into account are gG fuses, then a nominal value of 1250 A applies, which must be $F2 \times 1.6 \leq F1$. If one or both of the overcurrent protective devices is a circuit breaker, then their tripping characteristics must be compared with each other or with the fuse characteristics and, if applicable, tailored to each other, so that the curves are not affected (Fig. 54 and 55). In areas with short-circuit currents, they must have a sufficient time interval, so that the respective downstream overcurrent protective device can address the other and switch off.

A similar scenario applies in the event that a circuit breaker should represent the overcurrent protection for the SPD as F1, without a separate F2 overcurrent protective device. Then, the switching-off characteristics of the switch must be compared with the characteristics of the maximum overcurrent protection specified for the SPD by the manufacturer. This must not be exceeded in the range for short-circuit currents.

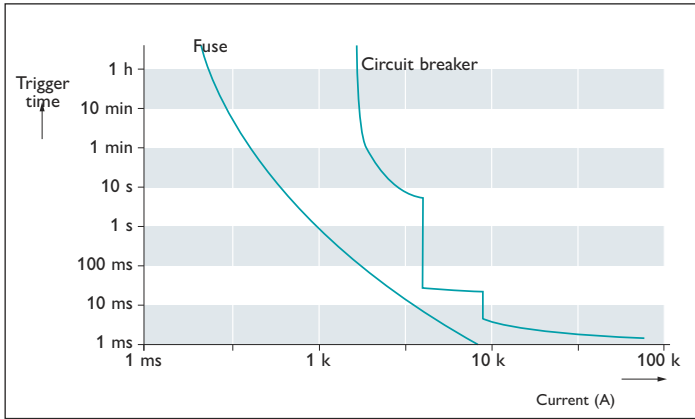

Fig. 54: Switching-off characteristics of a circuit breaker (F1) and a selective gG fuse (F2)

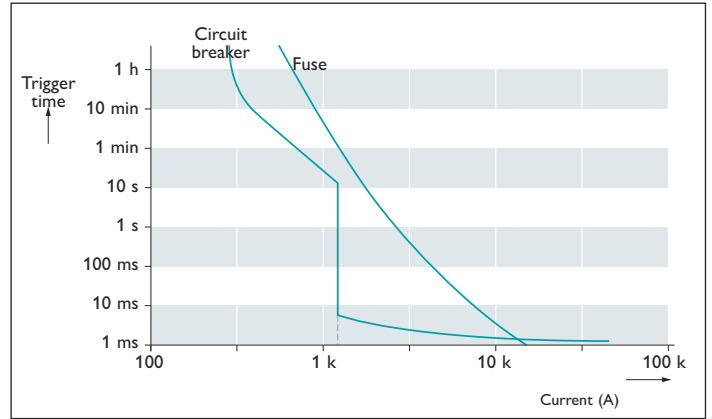

Fig. 55: Switching-off characteristics of a circuit breaker (F1) that is suitable as an upstream overcurrent protective device for an SPD with a maximum backup fuse of 315 A gG

SPDs with integrated overcurrent protection

Products that already contain corresponding fuses, such as the FLASHTRAB SEC HYBRID, represent a particularly straightforward solution for overcurrent protection of SPDs.

6.1.10 Safe Energy Control technology (SEC)

Phoenix Contact provides SPDs which are perfectly matched with other items from the range and that allow multi-

level protection concepts to be easily implemented: protection concepts with Safe Energy Control technology (SEC) combine maximum performance with a long service life, so that electrical fittings are always safely protected and maintenance costs are reduced. Installing SPDs with SEC technology is easy, cost-effective, and space-saving. The individual SPD types can be found in the product ranges as shown in Table 5.



Fig. 56: FLT-SEC-H-T1-1C-264/25-FM

FLASHTRAB SEC HYBRID

Thanks to the integrated fuse, no external protection elements are required, and space and costs are reduced. The protective effect is increased, as the voltage difference resulting from the fuse is already contained in the voltage protection level of the SPD. The short connecting cables required for SPDs are easy to set up (Fig. 56).

SPD type	Product range
Type 1	FLASHTRAB SEC
Type 2	VALVETRAB SEC
Type 3	PLUGTRAB SEC

Table 5: Product ranges with Safe Energy Control technology

Impact-free and durable

A consistent surge protection concept requires a powerful type 1 lightning current arrester. Conventional type 1 line follow currents load the installation with high line follow currents that can lead the upstream overcurrent protection to trigger. The SEC technology lightning current arresters are the first to feature spark gap technology with no line follow current. The avoidance of line follow currents benefits the entire installation. This means that not only the protected equipment, but the entire supply, including the SPD, are placed under minimal load by the discharge process. Maximum system availability is guaranteed because the fuse protection upstream is not triggered.

Backup-fuse-free solution for every application

The powerful lightning current arresters and surge protective devices with Safe Energy Control technology provide a solution without separate arrester backup fuse for all common applications. For applications where protecting the installation is the top priority, type 1 and type 2 SPDs can be used for main fuse ratings of 315 A gG without separate overcurrent protection. For applications beyond this scope, products are available with integrated surge-proof fuse, such as the FLASHTRAB SEC HYBRID. The type 3 SPDs from the PLUGTRAB SEC product range can be operated in branch wiring without any kind of backup fuse, which is also thanks to the integrated surge-proof fuses.

Compact and consistent pluggable design

With the FLASHTRAB SEC PLUS 440, the SEC range offers the most compact type 1 spark gap for this nominal voltage, with the VALVETRAB SEC the narrowest type 2 SPD, and with the FLASHTRAB SEC T1+T2, the only directly coordinated combination of

type 1 spark gap and type 2 varistor arrester in a confined space. All products in the SEC portfolio are pluggable, making maintenance a great deal easier.

6.1.11 Multi-level protection concepts

Thanks to the SPDs from the SEC range, multi-level protection concepts can be very easily put together for standard installations. Parameters such as the maximum continuous voltage, voltage protection level, and discharge current, are ideally tailored to one another.

Industrial production system with external lightning protection system

The protective zone transition $0_A \rightarrow 1$ is provided by a type 1 SPD from the FLASHTRAB product range at the point where the supply lines enter the building in the area of the low-voltage main supply. Depending on the grid system, the connection type to be selected, and

the voltage level of the supply, there are various SPD types and circuit versions. If, for example, it is a three-phase 230/400 V AC TN-C system, the FLT-SEC-P-T1-3C-350/25-FM is ideal (Fig. 58).

Alternatively, the protective device combination of FLASHTRAB SEC T1+T2 (Fig. 59) can also be used here. This directly coordinated combination of a type 1 SPD on a spark-gap basis and a type 2 SPD on a varistor basis provides many advantages when used directly in the main distribution.

In the further sub-distributions of the production system, for machine halls and office rooms, the protective zone transition is provided by $1 \rightarrow 2$, thanks to a type 2 SPD from the VALVETRAB SEC product range.

A supply as a TN-C system, as assumed in this example, is generally already converted into a TN-S system in the main distribution, so that the remaining installation is implemented with separately laid

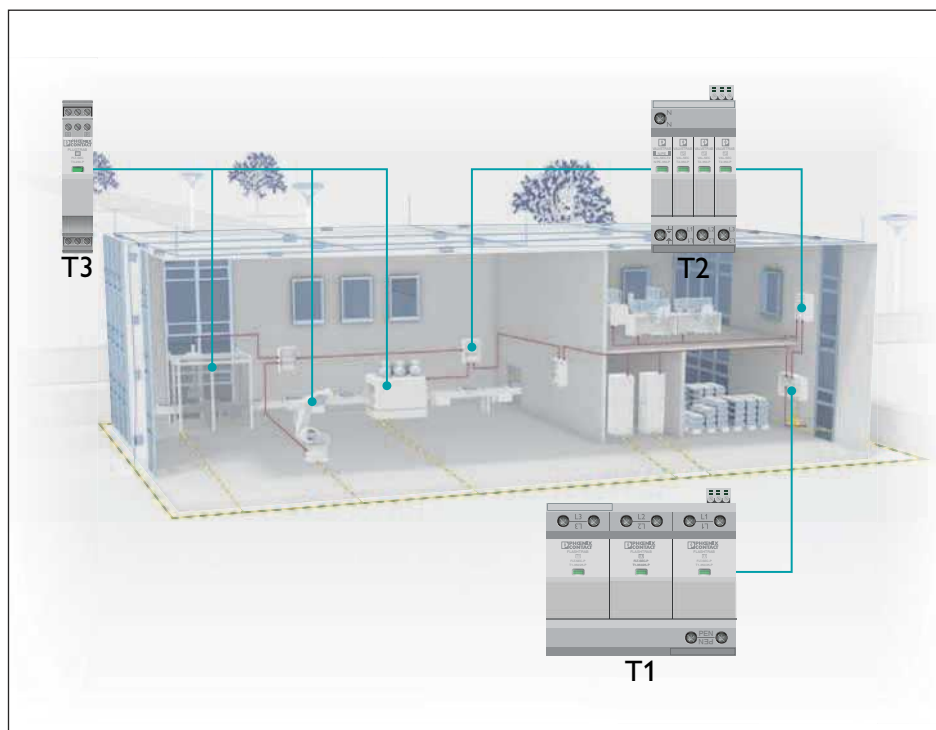

Fig. 57: Multi-level protection concept based on the example of an industrial production system

neutral and protective conductors. The VAL-SEC-T2-3S-350-FM is then offered as a type 2 SPD (Fig. 60). In the machine control cabinets and in offices, the 2 → 3 protective zone transition is provided by means of type 3 SPDs from the PLUGTRAB SEC range, directly upstream of sensitive end devices. For an end device operated with 230 V nominal

voltage, the PLT-SEC-T3-230-FM can then be used (Fig. 61).

FLASHTRAB SEC

The type 1 SPDs from the FLASHTRAB SEC family all use the spark gap technology that is free of line follow currents. They thereby guarantee maximum system

availability, as upstream overcurrent protection systems are not triggered as part of the discharge process.

FLASHTRAB SEC T1+T2

The unique SPD combination on the market, FLASHTRAB SEC T1+T2, optimally protects sensitive equipment by means of:

- Powerful spark gap to discharge direct lightning currents
- Varistor arrester to limit dynamic surge voltages
- Optimum energy distribution between the protective levels

VALVETRAB SEC

The VALVETRAB SEC T2 impresses above all due to the powerful, internal thermal disconnect device, in addition to the narrow design – just 12 mm per pole. The SPD can therefore be used without a further backup fuse

up to 315 A gG. It is also possible to operate it at the location installation with prospective short-circuit currents up to 50 kA.

PLUGTRAB SEC

The PLUGTRAB SEC T3 has integrated surge-current resistant fuses. As such, it can be used with end devices operated with both alternating current and direct current. The integrated overcurrent protection

enables connection in branch wiring without separate backup fuse, irrespective of the nominal current and the protection of the circuit.



Fig. 58: FLT-SEC-P-T1-3C-350/25-FM



Fig. 59: FLT-SEC-T1+T2-3C-350/25-FM



Fig. 60: VAL-SEC-T2-3S-350-FM



Fig. 61: PLT-SEC-T3-230-FM

6.2 Protection of DC systems with linear voltage sources

The operating behavior of different direct current systems with linear source characteristics can vary greatly from one to another. It is therefore impossible to easily select surge protective devices without precise knowledge of the respective systems. This particularly applies to systems with limited or low short-circuit currents.

Direct current power supply systems with linear source characteristics are mainly used for:

- Loads with low direct current power supply, e.g., programmable logic controllers or telecommunication systems
- Mobile loads, e.g, fork-lift trucks or onboard power systems
- Battery storage in UPS systems
- Computer centers
- Rail vehicles

Typical power sources of direct current power supply systems with linear source characteristics are:

- Controlled and non-controlled rectifiers with or without smoothing
- Regulated power supply units
- Charging power supply units
- Battery sets

Selecting surge protective devices

Selecting SPDs for direct current systems is generally significantly more complex than for alternating current power supply systems.

In the case of AC power supply systems, there is often only one power source; for DC systems, however, there are often multiple power sources with different operating behaviors. This particularly applies to battery-operated DC systems.

In the majority of AC systems, the minimum short-circuit current is high enough to cause upstream overcurrent protective devices to trigger in a few milliseconds. In the case of DC systems with limited or low short-circuit currents, however, it is very important that even minimal prospective short-circuit currents at the SPD installation site are detected, in order to meet basic safety requirements.

Significant design criteria for the selection of SPDs and corresponding overcurrent protective devices in DC systems are:

- Nominal voltage of the DC power source(s)
- Number, type, and operating behavior of the DC power source(s)
- Maximum and minimum prospective short-circuit current at the SPD installation location

Protective circuits for grounded and non-grounded DC systems

The preferred circuits for SPDs in DC systems conform to the CT1 connection type (refer to Fig. 50) and are either designed with one or two poles.

A 2+0 circuit is also required for grounded TN systems if the installation location of the SPDs is far away from the system's grounding point (Fig. 64).

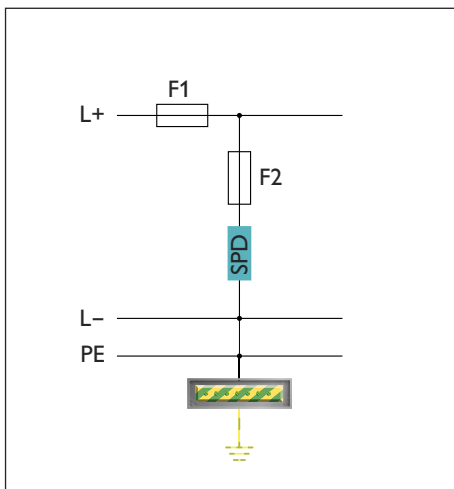

Fig. 62: 1+0 circuit for grounded TN systems at the grounding point

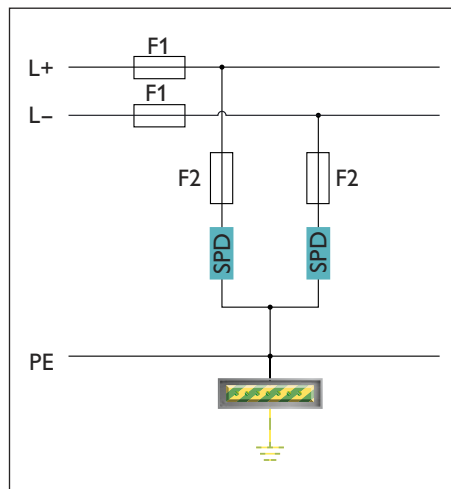

Fig. 63: 2+0 circuit for IT systems

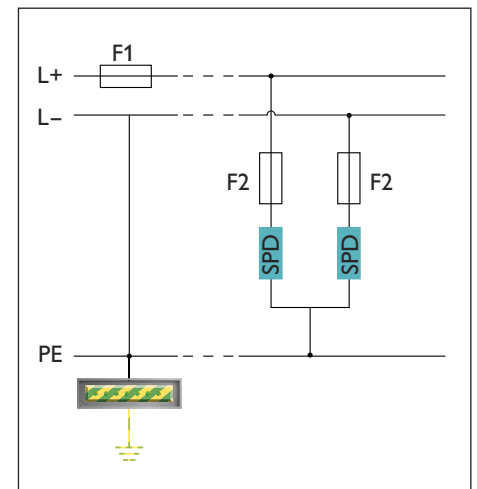

Fig. 64: 2+0 circuit for grounded TN systems that are far away from the grounding point

6.3 Protection of photovoltaic systems

The increasing number and variety of versions of photovoltaic systems presents a new challenge in terms of safety and reliability. This applies to all photovoltaic systems, such as rooftop systems on single-family dwellings, off-grid systems or free-standing systems.

Photovoltaic systems are often subjected to tough weather conditions, such as the effects of lightning, due to their exposed location. In order for the systems to be able to continue to operate safely and profitably, installing lightning and surge protection is recommended. Thanks to special standards and installation directives, it is possible to optimally plan and install photovoltaic systems.

IEC 61643-31 – requirements and test methods for surge protective devices in photovoltaic systems

Thanks to the IEC 61643-31 [8] product standard, it is possible to qualify lightning and surge protective devices according to their operating behavior and thereby guarantee the quality and safety of these products. The standard describes testing procedures for SPDs for use in photovoltaic systems and takes into account the peculiarities of the DC voltage and its properties. Among other things, special tests that replicate the

typical behavior of the photovoltaic system are carried out. This is because, under almost all operating conditions, the panels of a photovoltaic generator provide an almost constant current that is at the same time close to the short-circuit current of the system.

CLC/TS 50539-12 installation directive

In addition to the product standard, there is also the CLC/TS 50539-12 [13] installation directive. This provides key information for the installation of photovoltaic systems in the field. The directive differentiates between free-standing systems and structural systems (rooftop systems).

In the installation directive, there is a differentiation between voltage-switching and voltage-limiting components.

The combination of switching and limiting components in series and parallel arrangements is also taken into account. Table 6 provides the required values for the discharge capacity of voltage-limiting and combined SPDs that are switched in series in structural systems.

Voltage-limiting components or combined SPDs can thereby function as varistors or varistors and gas-filled surge protective devices in series connection (Fig. 65).

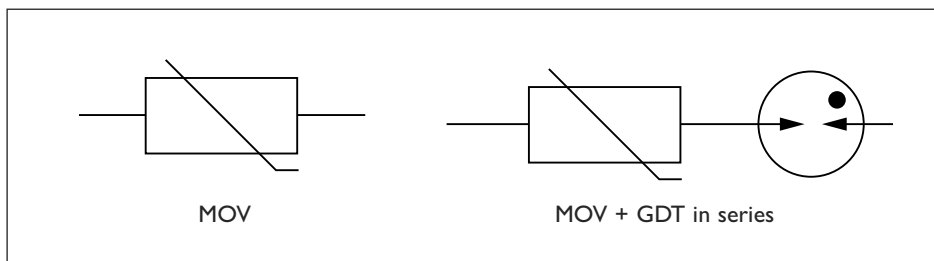

Fig. 65: Examples of voltage-limiting components or combined SPDs in series connection

LPL	Maximum Current (10/350)	Number of external protective devices							
		2				≥4			
		Per prot. mode		I_{total}		Per prot. mode		I_{total}	
		$I_{8/20}$	$I_{10/350}$	$I_{8/20}$	$I_{10/350}$	$I_{8/20}$	$I_{10/350}$	$I_{8/20}$	$I_{10/350}$
I or unknown	200 kA	17 kA	10 kA	34 kA	20 kA	10 kA	5 kA	20 kA	10 kA
II	150 kA	12.5 kA	7.5 kA	25 kA	15 kA	7.5 kA	3.75 kA	15 kA	7.5 kA
III or IV	100 kA	8.5 kA	5 kA	17 kA	10 kA	5 kA	2.5 kA	10 kA	5 kA

Table 6: Values for $I_{10/350}$ and $I_{8/20}$ for voltage-limiting and combined SPDs (voltage-switching and limiting components in series)

LPL	Maximum Current (10/350)	Number of external protective devices			
		2		≥4	
		Per prot. mode $I_{10/350}$	I_{total}	Per prot. mode $I_{10/350}$	I_{total}
I or unknown	200 kA	25 kA	50 kA	12.5 kA	25 kA
II	150 kA	18.5 kA	37.5 kA	9 kA	18 kA
III or IV	100 kA	12.5 kA	25 kA	6.25 kA	12.5 kA

Table 7: Values for $I_{10/350}$ and $I_{8/20}$ for voltage-switching and combined SPDs (voltage-switching and limiting components in parallel)

If voltage-switching SPDs or components are used in parallel to voltage-limiting components, then the surge current will be divided very unevenly. For this reason, other values are to be used (refer to Table 7).

Voltage-limiting components or combined SPDs can function as varistors or varistors and gas-filled surge protective devices in parallel connection (Fig. 66).

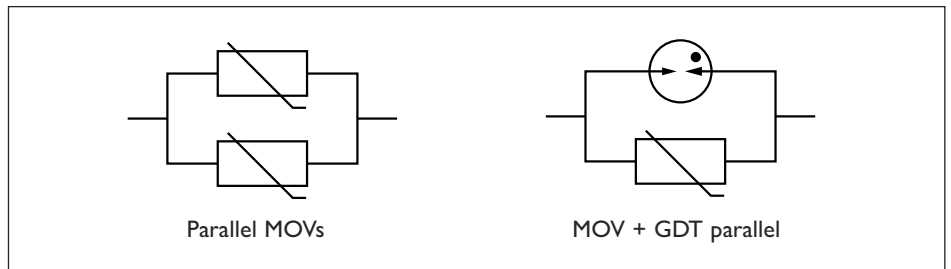

Fig. 66: Examples of voltage-limiting components or combined SPDs in parallel connection

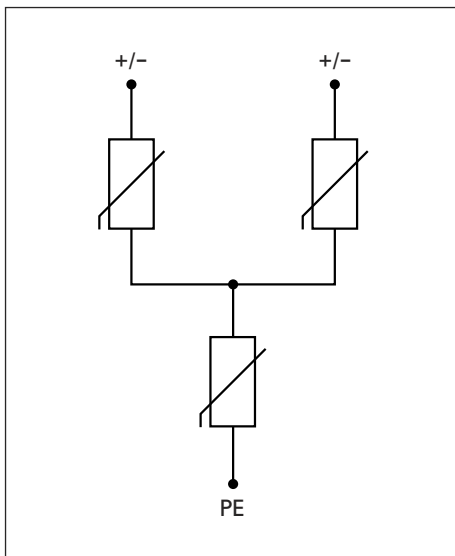

Fig. 67: Y-circuit consisting of three varistors

Advantages of the Y-circuit

Phoenix Contact provides all surge protective devices for photovoltaic applications based on voltage-limiting components in series. The circuit consists of three varistors in a so-called Y-circuit. In the event of failure, e.g., the short circuit of a varistor, a second varistor connected in series ensures that the current flow can be safely interrupted. In addition to a fast reaction time to surge

voltages, voltage-limiting components offer the advantage of a low voltage protection level compared with voltage-switching components.

Choosing protective devices

To select a suitable lightning and surge protective device, the following information is required:

- The Lightning Protection Level to be applied
- The number of external protective devices on the building

The majority of photovoltaic installations are designed for Lightning Protection Levels III or IV. In the event that the risk analysis of the photovoltaic system in question results in a higher Lightning Protection Level, the lightning and surge protective devices should be chosen with a higher discharge capacity. From experience, the majority of new constructions or existing buildings that are more than 10 meters wide are equipped with at least four protective devices. Corresponding values for the minimum requirements for lightning and surge protective devices can be taken from Tables 6 and 7.

For free-standing systems, Table 8 applies, which covers Lightning Protection Levels III and IV. This table once again differentiates between switching and limiting components in series and parallel.

Furthermore, CLC/TS 50539-12 describes the installation of SPDs depending on the line lengths between the devices to be protected and the equipotential bonding point.

Depending on whether an external lightning protection system is available or not, the required protective components should be selected on the AC side. If the building or the free-standing system has no external lightning protection system, then the inverter or string combiner box should be protected with a type 2 SPD. Provided the lines between the photovoltaic panels and the inverter exceed a length of more than 10 meters on the DC side, a coupled surge voltage can lead to the dielectric strength of the photovoltaic panel being exceeded due to oscillation effects, thereby leading to damage of the panel. In this case, placing another type 2 SPD directly on the panel is recommended. However, if an external lightning protection system is available, then a type 1 SPD should be installed on the building entry or in the string combiner box and a type 2 SPD should be installed on the AC side, upstream of the inverter. If the lines between the photovoltaic panels and the inverter

exceed a length of 10 meters on the DC side and on the AC side between the inverter and the equipotential bonding point, then a type 1 SPD is required.

LPL	Maximum Current (10/350)	SPDs, connected on the DC side I_{imp} in kA (10/350), I_n in kA (8/20)					
		limiting or combined SPDs (voltage-switching and limiting components in series)				switching and combined SPDs (voltage-switching and limiting components in parallel)	
		$I_{10/350}$		$I_{8/20}$		$I_{10/350}$	
		Per mode of protection	I_{total}	Per mode of protection	I_{total}	Per mode of protection	I_{total}
III or IV	150 kA	5 kA	10 kA	15 kA	30 kA	10 kA	20 kA

Table 8: Values for $I_{10/350}$ and $I_{8/20}$ for SPDs to protect a photovoltaic free-standing power system with several grounding points and a meshed grounding system

Building installation

Across the world, many photovoltaic systems are installed; among them, numerous rooftop systems (Fig. 68). Often when it comes to rooftop installation, it is a case of integration into the existing electrical building system. The following specifications must be observed here:

- Do not route the photovoltaic lines in parallel or close to the lightning conductor of the external lightning protection system.
- Avoid the effects of lightning on the protective conductor by means of a galvanic connection in which the lightning surge protective devices are installed upstream of the device to be protected.
- Observe the separation distances between the module frame and

the external lightning air-terminal. Connect module frames to the separate ground potential. During installation it is important that the existing system is not disturbed and that it is sufficiently protected from external influences. This relates to the entire installation, from the module right through to the inverter on the DC side and of course from the inverter to the main connection on the AC side. In order to enable lightning and surge protection, photovoltaic systems are connected to the equipotential bonding strips in the main distribution. As a consequence of this, the lightning effects can enter via the DC and AC side in the non-protected state. For this reason it is crucial that the entire system is considered and devices at risk are protected. For data and communication

units, comprehensive protection is just as important and should be taken into account at the planning stage. Here, slight surge voltages can couple in and damage the inverter or evaluation unit.

Free-standing systems

Today, large free-standing systems (Fig. 69) are mainly used as a source of income. To reduce system costs, increasing the system availability and minimizing the failure quota is important. To this end, all components must be carefully selected and correctly installed.

As such, surge protective equipment that has been developed according to the valid product standard, IEC 61643-31 [8] for SPDs for use in photovoltaic installations, should be installed.

For the majority of constellations, a type 2 SPD that is directly installed at the DC input of the inverter is sufficient. For effective protection, the data and communication lines of the inverter must also be protected in addition to the DC and AC side.



Fig. 68: Rooftop system on a single-family dwelling

Protective devices for systems of all types

Regardless of whether it is for rooftop systems on single-family dwellings, off-grid systems or free-standing systems – for the safe operation of a photovoltaic system, a lightning and surge protection concept must be created as early as the planning stage. Phoenix Contact provides powerful SPDs for all areas of application.

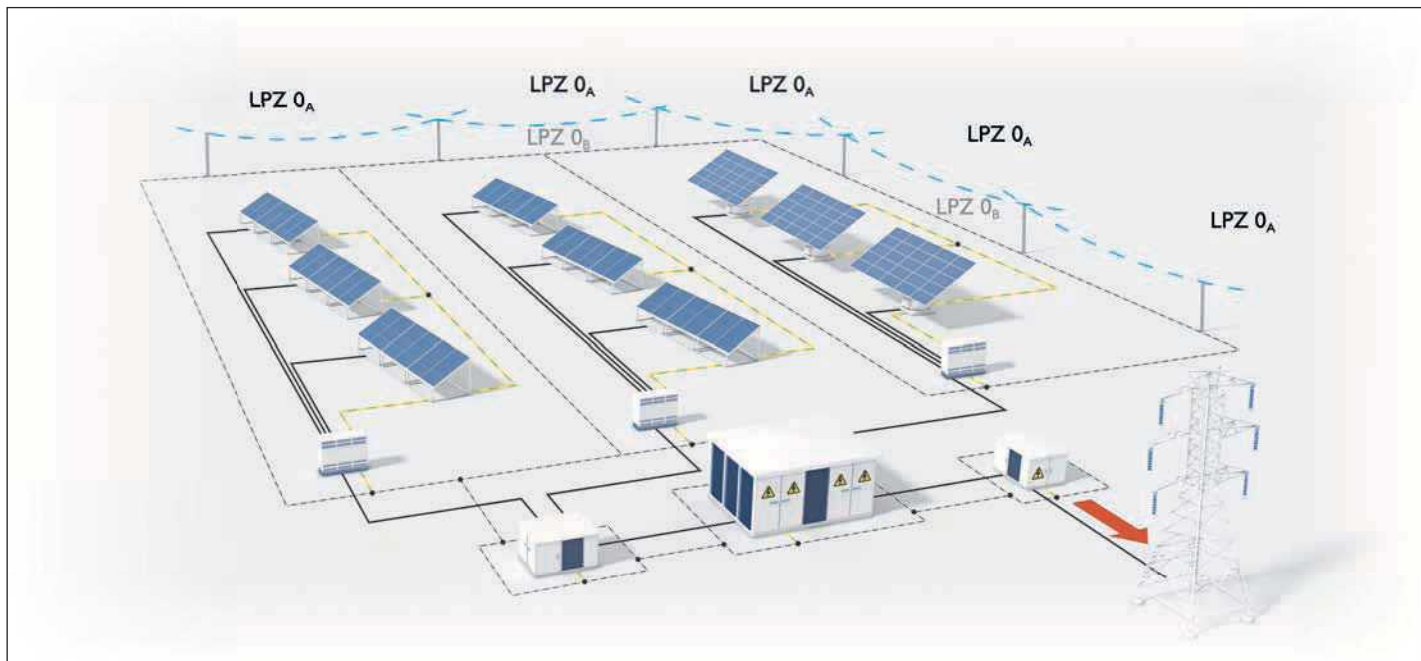

Fig. 69: Free-standing system with external lightning protection system

New design for system voltages up to 1500 V DC

In times in which solar subsidies are being drastically reduced, it is essential to minimize system costs accordingly to ensure an acceptable return. Thanks to an increased voltage of up to 1500 V DC, this is perfectly feasible. Due to the associated lower string currents, in practice this means customers use lines

with a smaller cross section, and thereby achieve cost savings in terms of cabling. In total, the balance of system (BOS) costs can be reduced through fewer string combiner boxes and lower cabling expenses. Inverter manufacturers also benefit from this. With a system voltage of 1500 V, the inverter performance can be increased by up to 20%. This makes the photovoltaic system more

cost-effective and efficient. However, this is only possible if all the components are designed for these voltages.

VALVETRAB-MB-...-DC-PV

To keep pace with this trend, the new surge protective devices of the VAL-MB product range were developed for voltages up to 1500 V DC and with a total discharge capacity of 12.5 kA I_{Total} (10/350 μ s).

What's more, the new product range completely fulfils the product standard requirements and the installation directive for Lightning Protection Levels III and IV.



Fig. 70: VAL-MB-T2 1500DC-PV/2+V-FM

6.4 Protection of signal transmission circuits in MCR technology

Interference-free transmission of signals plays a central role in the field of measurement, control, and regulation technology (MCR technology). Error-free operation of building services management, manufacturing or process technology necessarily demands a high level of availability of the signals transmitted. However, these are exposed to an increasingly active electrical environment. This particularly applies to weak measured values that are delivered by sensors. If the measured values are low voltages or electric currents that must be securely transmitted, carefully conditioned or evaluated, then there is an increase in the electromagnetic and high-frequency interference they are exposed to.

Reasons for this are:

- An increasing number of electrically operated components in all performance classes, especially motors operated via frequency inverters and other actuators.
- The increasing miniaturization and packing density of device components.
- A growing volume of wireless communication and control equipment.
- Digital systems that work with ever higher transmission frequencies.

Insufficient attention given to the above disturbance variables, incorrect adjustments or lack of planning can all affect interference-free signal transmission.

Surge voltages that are influenced by the effects of lightning can also have a negative impact on the functioning and availability of electronic modules in measurement and control technology. Damage caused by surge voltages in MCR technology systems can, however, be effectively prevented by using tailor-made surge protective devices.

Depending on the potential for risk and the requirements of the protection

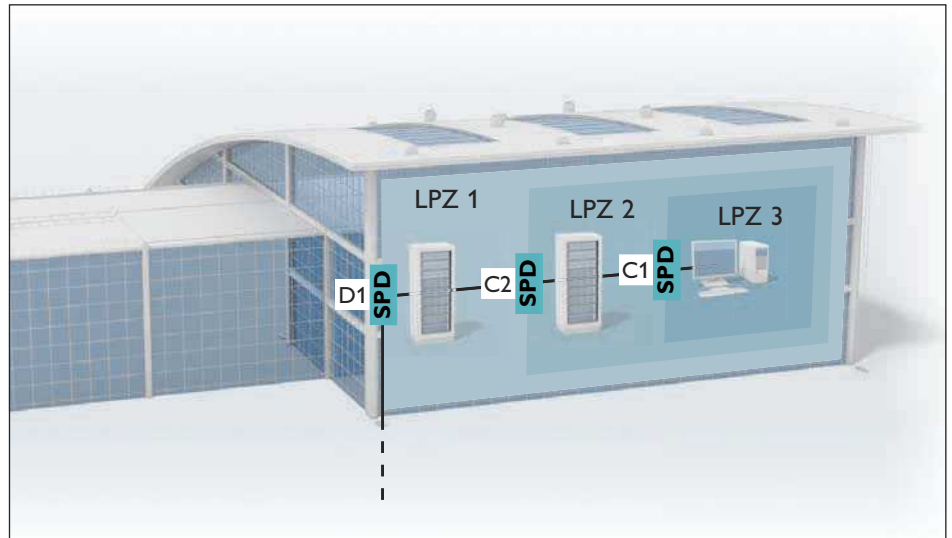

Fig. 71: Lightning protection zones and classification of protective devices for MCR and IT systems according to IEC 61643-22 [7]

level, surge protective devices with combined protective circuits or with individual components are used. These are installed directly upstream of the signal inputs to be protected. The circuits of the surge protective devices to be used are adapted to the various signal types.

Divisions within the standard

The requirements and assignment to protective zones are described in detail in standards IEC 61643-21 [7] and IEC 61643-22 [16]. The performance of protective modules for MCR technology is described by IEC categories D1, C2, and C1. (Fig. 71)

Table 9 explains the correlations between lightning zone transitions and the IEC category of the MCR protective devices in comparison to the power supply protective devices.

In contrast to installing SPDs for power supply systems, a surge protective device does not have to be installed at every zone transition in the case of MCR signals (refer to IEC 61643-22). In practice, the signal cabling from the field

is not usually separated at every zone transition, helping to reduce installation work. Multiple protection levels are generally combined in one MCR surge protective device. As a practical solution, this protective module can be installed upstream of the device to be protected (e.g., controller input)

Zone transition	$0_A \rightarrow 1$	$1 \rightarrow 2$	$2 \rightarrow 3$
Corresponds to SPD type IEC-61643-21	D1	C2	C3
Corresponds to SPD type IEC-61643-11	1	2	3

Table 9: Lightning protection zone transitions and corresponding SPD types

Choosing surge protective devices

Selecting surge protective devices for MCR technology depends on several factors. The product required is primarily determined by the type of signal circuit to be protected.

Typical signal transmissions are:

- Binary signals
- Analog loops
- Temperature measurements (two-, three-, and four-terminal sensing)
- Multi-polar binary signals

Other factors involved in selection are:

- Signal voltage of the signal to be transmitted
- Surge withstand capability of the end device interface to be protected
- Transmission frequency of the signal

6.4.1 How the circuits work

Basic circuits

In measurement and control technology, there are different applications and types of signal. Various protective circuits are therefore available that are specially optimized for the application. First of all, a distinction is made between signal types that are designed as a closed circle (loop) and signals with a common reference potential or a shared return conductor.

The stand-alone closed circles (loops) are often designed so that they are

insulated from the ground potential for interference immunity. A frequently encountered application of this type is the 4...20 mA current loop for transmitting measured values.

To ensure insulation in the application does not fail going forward, the surge protective devices are designed accordingly. Gas-filled surge protective devices (gas discharge tubes, GDT) have a corresponding insulation behavior. When operated, they guarantee insulation between the signal wires and the ground potential. In the event that a surge voltage is applied, the GDT effectively discharges the transients to ground and limits the voltage so that the dielectric strength of the end device is not exceeded. The typical dielectric strength of the end device is 1.5 kV. In addition to protecting the dielectric strength, the protection between the signal wires and thereby the electric strength is particularly important in the area of MCR surge protection. The end devices are often much more sensitive to potential differences of this nature, as sensitive semiconductor components in the terminal device are directly affected. Often, the corresponding electric strength of the devices is below 100 V. The protection stage affected in the surge protective device implements a fast-responding suppressor diode (transient voltage suppressor diode, TVS diode), with a correspondingly high

voltage protection level.

The special functioning of the protective circuit with decoupling resistors is described in detail below.

In cases where the decoupling resistors in the common mode paths are damaging, it makes sense to choose a circuit version without decoupling. This may be the case with the Pt 100 two-conductor measuring circuits.

Surge protection for all signal types

The huge variety of different signal types, field buses, and interfaces requires a tailor-made product and a wide product range. When choosing the right MCR SPD, the STOP-IT (Selection Tool of Protection for Information Technology) selection guide is invaluable. It is available online on the Phoenix Contact website.

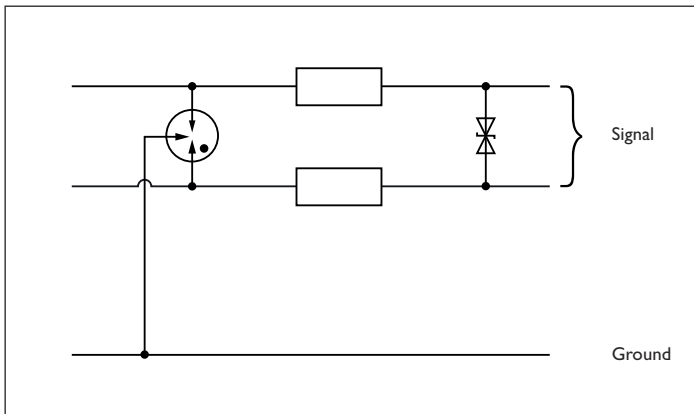

Fig. 72: Basic circuit for insulated signal circuits

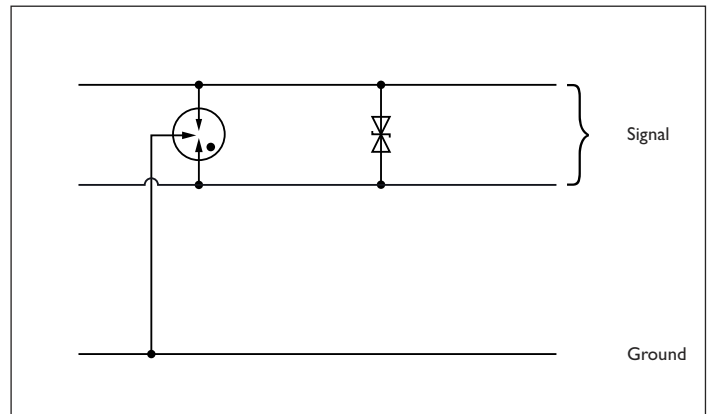

Fig. 73: Basic circuit for insulated signal circuits (without decoupling resistors)

where the resistors can falsify the measuring result. Even in the event of actuator circuits with higher nominal currents, this type of protective circuit is used.

Applications with common reference potential require another protective circuit, as the sensitive semiconductor components in the end devices can also be damaged by transient overvoltages between the signal wires and the reference potential. For this reason, in such cases the TVS diodes are switched between each wire and the reference potential. In cases where the reference potential is grounded, the surge protective device can be used, as shown in Fig. 74. In the majority of cases, a direct connection between the common reference potential (e.g., ground) and the ground potential is not permitted or desired. To nevertheless be able to provide protection to insulate the system from the ground potential, circuit versions with additional gas-filled surge protective devices are a logical choice (Fig. 75).

How the coupling elements work

Coupling elements increase the performance of the protective circuit if a particularly large pulse between two signal wires has to be limited. The surge voltage from the field side is applied to the unprotected side of the surge

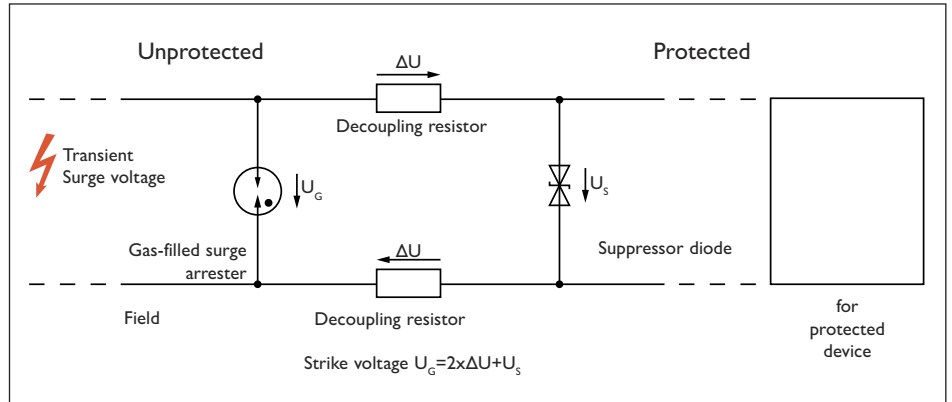

Fig. 76: Two-stage protective circuit

protective device (Fig. 76). Due to the low response voltage, the suppressor diode is initially low-resistance. It results in a compensating current across the coupling resistors and the diode. Due to the voltage drop on the diode and resistors, a voltage arises that reaches the level of the strike voltage of the gas-filled surge protective device. As soon as this also becomes low-resistance, it discharges the power of the surge voltage.

The circuit is designed in such a way that the gas-filled surge protective device is fully activated before the diode reaches the performance limit. Once the transient is no longer present, the short-circuit current is extinguished, as the arc burn voltage of the gas-filled surge protective device is higher than the

operating voltage of the application.

The products are designed in such a way that not only an individual transient, but many overvoltage events can be mastered. The testing and maintenance intervals can be set up accordingly for the systems. Depending on the risk assessment, in practice, SPDs tests are carried out every one to four years.

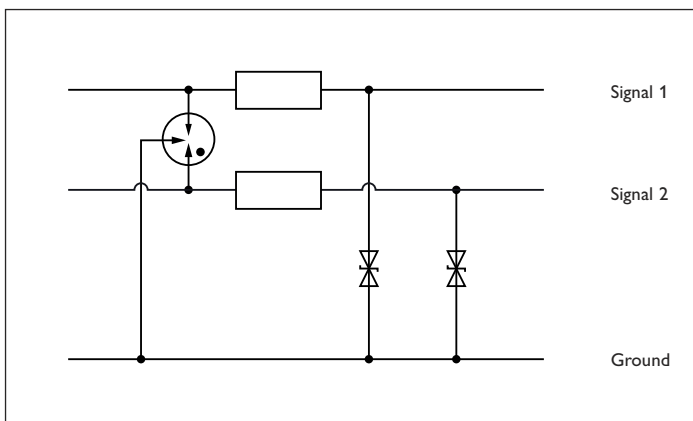

Fig. 74: Basic circuit for applications with common reference potential, directly grounded

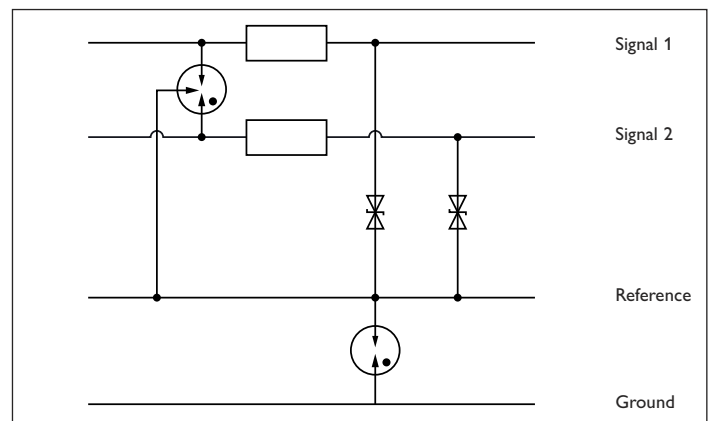

Fig. 75: Basic circuit for applications with common reference potential, indirectly grounded

6.4.2 Function-monitored protection

The PLUGTRAB PT-IQ protective device system (Fig. 77) is an especially convenient solution. The SPDs monitor themselves, thanks to an intelligent monitoring system. They report the respective function status. For this purpose there are LED indicators on the protective plug in green, yellow, and red. Yellow indicates that the protective device is reaching the end of its service life. Yellow means that the protective function is still fully guaranteed. This early warning indicator enables the replacement to be planned at an early stage. A replacement is recommended and must be carried out when the red LED lights up at the latest.

A pluggable signal and supply bus runs along the DIN rail, thereby minimizing wiring effort. The protective modules receive the supply voltage from this and report their status to the central controller at the start of the protective

device series. Here the signal is also displayed visually and made available via a floating contact as a remote warning signal. Via this floating contact, the status of the SPDs can be forwarded via the various transmission media (bus or wireless systems).

PLUGTRAB PT-IQ

Thanks to this system, the user knows the status of their system at any time, regardless of location. The devices are available with screw terminal blocks or with a Push-in connection. Another version is suitable for use in Ex i circuits.



Fig. 77: PT-IQ protective device system with function status display

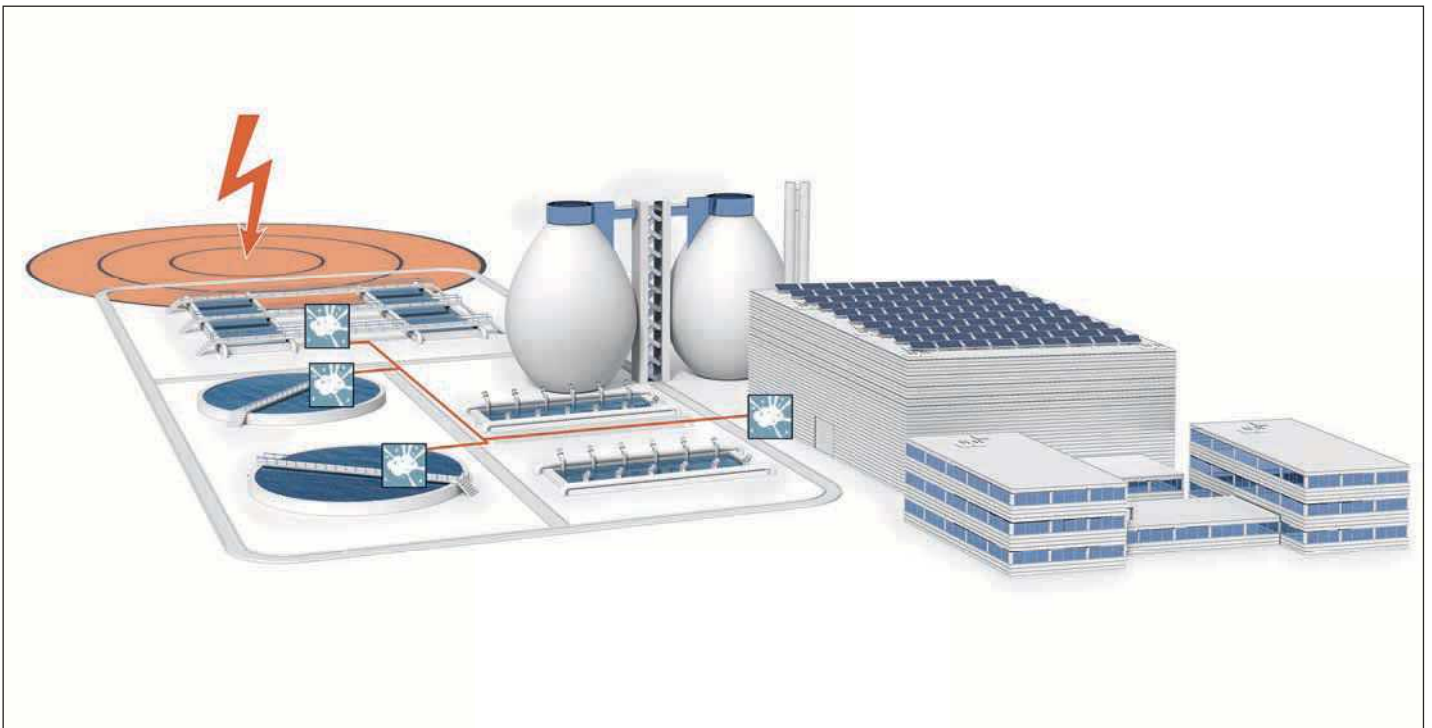

Fig. 78: Coupled surge voltages on signal lines in a sewage works

6.4.3 Protection in the field and the control center

In most cases, transient overvoltages arise on signal lines due to indirect couplings. Systems that are particularly at risk are those that are very extensive and those that have high numbers of lines laid through the free-standing area (LPZ 0) (strong meshing) (Fig. 78).

Be aware that the hazards must be made clear at both end points of the lines. It is therefore recommended that the surge protection is taken into account both in the field as well as in the control center (Fig. 79).

Today's requirements

The surge protection products that are mounted on a DIN rail often, in line with today's state-of-the-art technology, have an installed, galvanic conductive base contact that is designed to discharge the transients to ground. This means that the connection to the equipotential bonding on the DIN rail can be made to ground. For installation in the field, special designs are available that can be directly attached to the threaded screws on the measuring transducers or actuators. The protective circuits are enclosed in a stable metal housing and have an IP protection class which enables direct use in open areas. In this case, the discharge to ground takes place via the local equipotential bonding connection on the field device.

6.4.4 Surge protection in explosion-proof areas

Explosive atmospheres can frequently occur in the chemical and petrochemical industries due to industrial processes. They are caused, for example, by gases, fumes or vapors. Explosive atmospheres are also likely to occur in mills, silos, and sugar and fodder factories due to the dust present there. Therefore, electrical devices in potentially explosive areas are subject to special directives. This also

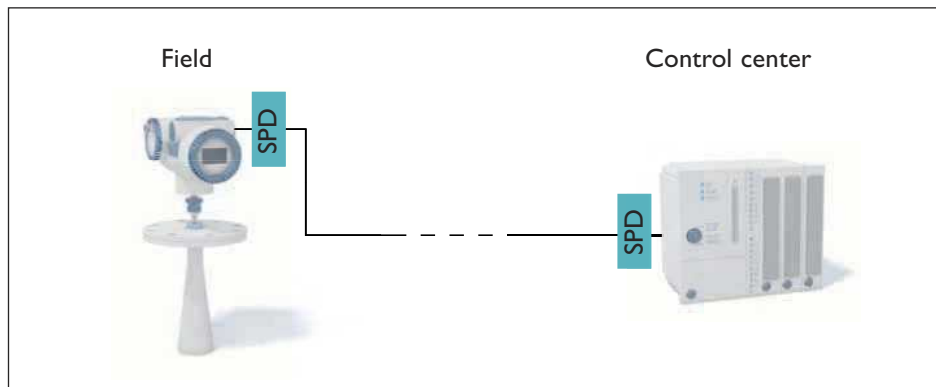

Fig. 79: Surge protection in the field and the control center

applies to surge protective devices that are used in these types of application.

Systems often contain signal circuits with Ex i protection (intrinsic safety) according to IEC/EN 60079-11. A circuit is described as intrinsically safe if the current and voltage are limited to such an extent that no spark or thermal effect can cause a potentially explosive atmosphere to ignite. No special authorization (e.g., fire certificate) is required for the maintenance of intrinsically safe circuits. The cables of the intrinsically safe circuits can be short circuited or interrupted without having to de-energize the system. On top of this, the equipment may be installed in EX zone 0, depending on the respective protection level. If surge protective devices are to be used in

such applications, take note of the corresponding approval.

Zone 0

Area in which a hazardous explosive gas atmosphere is present for continuous, frequent or long periods. These conditions are usually present inside containers, pipelines, apparatus, and tanks.

Zone 1

Area in which a hazardous explosive gas atmosphere is to be expected only occasionally during normal operation. This includes the immediate area surrounding zone 0, as well as areas close to filling and emptying equipment.

Certified protective devices for potentially explosive areas

With the PLUGTRAB, TERMITRAB, and SURGETRAB product ranges, Phoenix Contact provides solutions that have ATEX approval according to directive 94/9/EC and that can be installed in intrinsically safe circuits up to Zone 1.



Fig. 80: Surge protection for direct mounting on field devices, SURGETRAB

Zone 2

Area in which a hazardous, explosive gas atmosphere is not expected during normal operation; however if it does occur, it is only for a short time. Zone 2 includes areas that are used exclusively for storage, areas around pipe connections that can be disconnected, and generally the intermediate area surrounding Zone 1.

6.4.5 Lightning protection equipotential bonding for pipelines

A long service life is vital for the cost-effective operation of pipelines. Active corrosion protection systems are used to protect against rust. These require the metal pipes to be insulated against ground potential for operation.

In order to protect the pipe insulation (coating) and the insulating flanges against damage caused by surge voltages, isolating spark gaps are used (Fig. 83). If a surge voltage occurs, for example due to a lightning strike, the isolating spark gap becomes low-resistance. The lightning current is discharged to ground via a specific route, thereby ensuring lightning protection equipotential bonding.

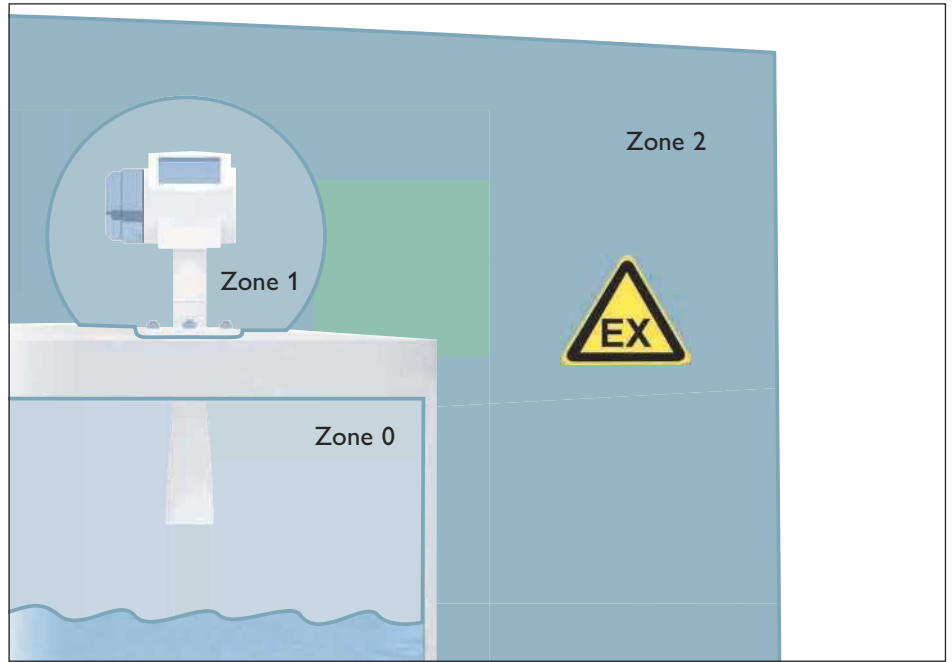

Fig. 81: Zone division based on the example of a liquid tank with fill level sensor



Fig. 82: Typical area of application: gas compression station



Fig. 83: Installation example based on an insulated flange

6.5 Protection of signal transmission circuits in information technology

Communication via data networks is a part of daily life in all areas of the company.

The interfaces operate with low signal levels at high frequencies. This makes them particularly sensitive to surge voltages and can lead to the destruction of electronic components in IT systems. In addition to protection that is tailored to these systems, SPDs must also exhibit high-quality signal transmission behavior, as otherwise malfunctions are to be expected in the data transmission. This aspect is becoming ever more important in the face of constantly increasing data transmission rates. To this end, when developing new SPDs for IT systems, the focus is on implementing high-quality signal transmission behavior. It is evaluated based on the ISO/IEC 11801 or EN 50173 standards.

Furthermore, in this area of application, a wide range of connection technology is encountered. For this reason the protective devices must correspond to the electrical specifications and also be adapted to the interfaces to be protected. The SPD versions often differ only in their design and connection technology.

The protective circuits usually combine fast-responding, low-capacitive suppressor diodes with powerful,

gas-filled surge protective devices. Where required by the circuit technology, ohmic resistors decouple the two protection stages.

6.5.1 Ethernet and token ring interface

The architecture or structure of a network installation and the type of data transfer between the terminals in the data network are referred to as the topology.

In local networks, they have been tried and tested as bus, ring, and star topologies that can also be combined. To transmit information in data networks, twisted pair or fiber optics are used.

Data transmission requirements

Ethernet and token ring interfaces have been used for years. Ethernet systems have prevailed, however, due to their transmission speed and compact connectors. The transmission behavior of the Ethernet system is defined in standard IEEE 802.3. The transmission speed is up to 10 Gbps.

The transmission speed (Table 5.1.1a) is defined according to the power categories (Cat. 5 - Cat. 7).

New systems with a higher transmission frequency work according

to Cat. 6 and Cat. 7, and in the future will work according to Cat. 8.1 or Cat. 8.2.

Protective devices with RJ45 connection, where all eight signal paths are protected, are universally suited to the Ethernet, Profinet, and token ring interfaces.

Power over Ethernet (PoE)

Power over Ethernet (PoE) is a process in which the auxiliary energy for the connected devices is also transmitted via the Ethernet data cable.

The auxiliary power is either applied to the unused wire pair (mode b, Fig. 86) or is supplied between the signal wire pairs as phantom power (mode A, Fig. 85). In line with IEEE 802.3af, a maximum power of 13.5 W can be transmitted using this procedure. The following IEEE 802.3at standard already enables 25.5 W with PoE. POE++ is being debated, with which even higher transmission capacities will be able to be achieved.

6.5.2 Serial interfaces

Serial interfaces are used to exchange data between computers and peripheral devices. In the event of serial data transmission, the bits are transmitted

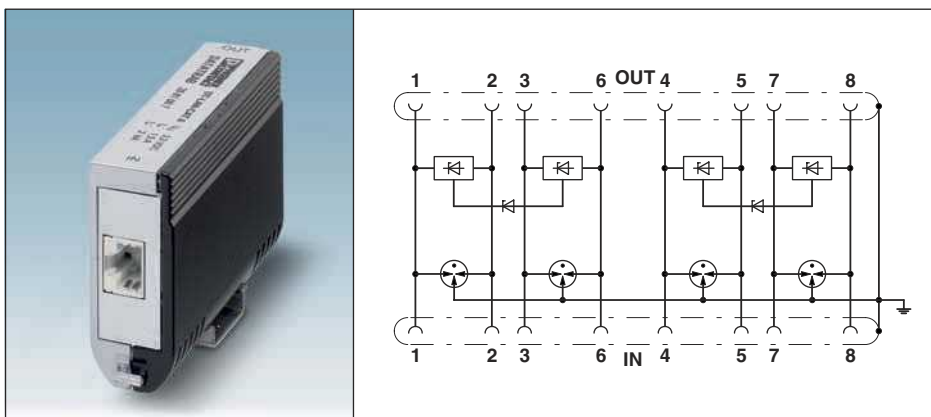

Fig. 84: DT-LAN-Cat.6+ - SPD for information technology

DT-LAN-Cat.6+

The DT-LAN-CAT.6+ protective device optimally protects sensitive equipment, as quickly reacting protective components are used for the data cabling as well as for the PoE system.

	Area of application	Category	Mbps	Cable	Connection
100 Base TX (Fast Ethernet)	LAN, structured building cabling	5	100	2 - 4-pair twisted pair	RJ45, pair: 1-2, 3-6, or 4-5, 7-8
1000Base T (GIGABIT Ethernet)	LAN, structured building cabling	5e, 6	1000	4-pair twisted pair	RJ45, pair: 1-2, 3-6, + 4-5, 7-8
10 GBase T (GIGABIT Ethernet)	LAN, structured building cabling	6a	10,000	4-pair twisted pair	RJ45, pair: 1-2, 3-6, + 4-5, 7-8
10 GBase T (GIGABIT Ethernet)	LAN, structured building cabling	7	10,000	4-pair twisted pair	RJ45, pair: 1-2, 3-6, + 4-5, 7-8

Table 10: Transmission speed vs. performance categories

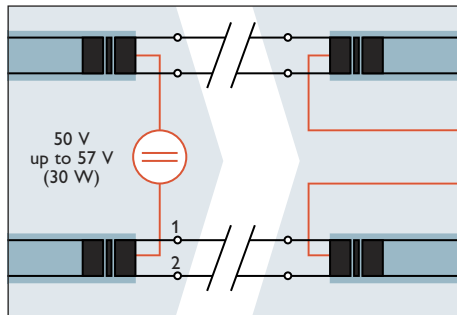

Fig. 85: Transmission of auxiliary power by means of phantom supply (mode A)

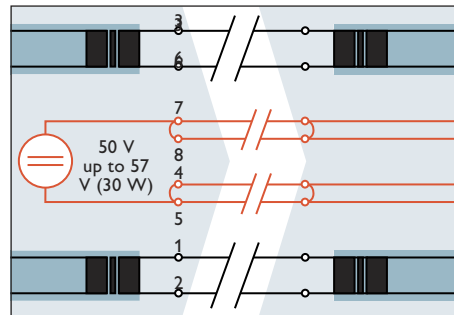

Fig. 86: Transmission of auxiliary power by means of phantom supply (mode B)

over a cable (in series), one after the other. Particularly common are:

RS-485 and PROFIBUS interfaces

The RS-485 serial interface is used on the Intel bitbus and is closely related to the RS-422. This symmetrical data transmission generally functions via a pair of signal wires. Versions with two pairs of signal wires and a ground are also used.

In older systems, the signal voltage of this interface amounts to ground -7 V and +12 V. In newer systems, a version with TTL level, e.g., +/- 5 V is used.

The PROFIBUS interface is a further development of the RS-485 interface. It uses the physical characteristics of the RS-485, but with transmission rates of up to 12 Mbps. These interfaces are used for other applications in the time and machine data acquisition device field.

D-SUB attachment plugs for DIN rail mounting or DIN rail modules with screw terminal blocks are frequently used as protective devices.

V.24 interface

The V.24 or RS-232 serial interface works with an asymmetrical signal transmission. One transmit and one receive signal each have a common reference potential (ground). In addition, up to five control signals can be transmitted. This yields a maximum of eight active signals including ground. Connection is usually via D-SUB 25, D-SUB 9 or screw terminal blocks.

V.11 interface

The V.11 or RS-422 serial interface works on the basis of symmetrical signal transmission. The transmission path can be up to 1000 m. The transmit and

receive signal are each transmitted via a pair of signal wires. In addition, a ground is routed as a reference potential, so that defined voltage conditions prevail at the connected interfaces.

TTY interface

The TTY interface works serially and symmetrically via two signal wire pairs. When a signal voltage of up to 24 V occurs, a current signal is analyzed. Here, 10 – 30 mA is the logical 1 and 0 – 1 mA the logical 0. Standard data transmission rates are 9.6 kbps or 19.2 kbps.

6.6 Protection of signal transmission circuits in telecommunications technology

Telecommunication end devices are today an inherent part of office electronics. Today, unrestricted operational availability of modern, fast communication systems is an absolute necessity, especially in the business sector. The specific use of suitable surge protective devices can prevent the sudden and unforeseen failure of important telecommunications equipment. Suitable protective devices for DSL data transmission and for analog signal interfaces are available.

The protective circuit is mainly made up of a combination of Trisil diodes and powerful, gas-filled surge protective devices. The gas-filled surge protective devices are designed as three-electrode gas discharge tubes. The central electrode provides common mode voltage protection on the ground. Where required by the circuit technology, ohmic resistors decouple the two protection stages.

To protect against voltages from the power supply network (power cross)

the three-electrode gas discharge tubes are equipped with thermal protection. Common interfaces in telecommunications are:

xDSL interface

DSL interfaces (digital subscriber line) provide Internet connections with speeds of 1 Mbps (ADSL) up to 100 Mbps (VDSL). The transmission frequency is between 2.2 MHz and 17.7 MHz. The nominal voltage for the protective circuit on suitable protective devices depends on whether a DC supply is also transmitted. Typical nominal voltage values for applications are:

- Without power supply: < 24 V DC
- With power supply: ≥ 110 V DC

When compared internationally, the transmission frequency in the DSL range can vary by some 100 kHz depending on the region. For this reason, their cut-off frequency should be taken into account when selecting a protective device.

Analog telecommunications interface

Today, analog telecommunication is only found in simple telephone connections. Protective devices for this should have nominal voltages of 180 V. Generally, DSL protective devices (Fig. 87) can also be used for analog telecommunication.

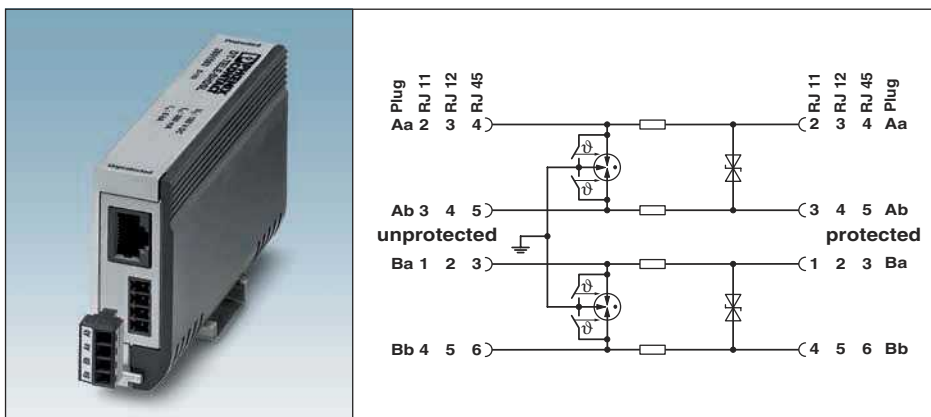

Fig 87: DT-TELE-RJ45 - SPD for telecommunications systems

DT-TELE-RJ45

The DT-TELE-RJ45 protective device protects fast VDSL connections with its very low attenuation. Thanks to the universal connection technology (RJ45, RJ12, RJ11, and pluggable screw connection) the product is ideal for any application.

6.7 Protection of signal transmission circuits in transceiver systems

Transceiver systems are generally considered to be particularly susceptible to surge voltages.

Antenna cables which extend beyond the building and are generally particularly long, as well as the antennas themselves, are directly exposed to atmospheric discharges. For this reason, cables with a coaxial structure and therefore favorable EMC properties are used. The shield of the antenna cable can be either grounded or floating, depending on the system conditions. However, the risk of surge voltage coupling in antenna cables is not completely eliminated. Surge voltages can even reach the sensitive interfaces of transceiver systems via this cable path.

The high frequencies of wireless transmission require the use of protective devices with low self-capacitance or low insertion loss with good impedance matching. Nevertheless, a good level of protection is required with high discharge capacity. For this reason, most protective devices are equipped with powerful gas-filled surge protective devices or with the Lambda/4 technology. The Lambda/4 technology uses a short circuit between the inner conductor and the shield. The length of the cable between the short circuit and the inner conductor matches the frequency that is allowed to pass through without attenuation. A great

advantage in this technology is achieving a very good (low) voltage protection level, as the protective device functions as a short circuit in the frequency range of surge voltages. However, it must be taken into account that the cable that is connected to the Lambda/4-protective device cannot use a DC power supply. Relatively wide bandwidth signals (e.g., 0.8 – 2.25 GHz) can be transmitted by means of HF-optimized Lambda/4 protective devices. Fig. 88 shows a typical design of a protective device with Lambda/4 technology.

The most common applications for SPDs in telecommunications are:

Antenna connection of television and radio receivers

The protective devices for radio and television devices are generally mounted between the antenna wall connection and the outgoing antenna cable. For satellite receivers, there are multi-channel protective devices for wall mounting. Broadband cable and antenna connections generally have TV and RF connectors according to DIN 45 325. Satellite receivers are connected via F connectors.

Video communication

The applications in video communication extend from monitoring buildings, public areas, and institutes right through

to sport and leisure facilities. The permanent availability of this monitoring equipment requires suitable surge protective devices. As a general rule, coaxial attachment plugs are used as protective devices, with BNC or TNC connectors.

Radio link and mobile phone systems

Radio link technology enables wireless transmission of data. The radio waves produced are transmitted in multiplex mode using panel antennas with a carrier frequency of between 1 and 40 GHz. Common types of antennas are parabolic reflectors, shell antennas, and horn antennas. The nominal frequencies of useful signals in this range are between 0.8 GHz and 2.7 GHz. N, SMA or 7/16 connectors are used as the connection technology for the protective devices.

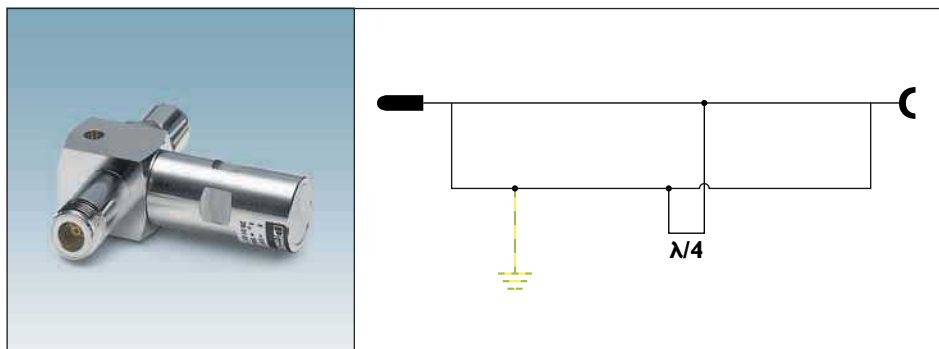

Fig. 88: CN-LAMBDA/4 - protective device with Lambda/4 technology

CN-LAMBDA/4

Using the CN-LAMBDA/4-2.25 protective device, the widest range of transmission systems can be actively protected in the GHz range. This is achieved by means of a broadband LAMBDA/4 technology.

7 Glossary

ATEX

ATEX is a widely used synonym for the ATEX directive issued by the European Union. The ATEX designation is derived from the French abbreviation for “atmosphères explosibles”.

Binary signals

By binary signals, we mean digital signals that only take on the state of “high” or “low”. Generally, these signals relate to a common reference potential or a shared return conductor.

Dielectric strength

Insulation strength of the electrical circuits of a piece of equipment when compared to withstand and surge voltages with amplitudes above the maximum continuous voltage.

EMC

EMC stands for electromagnetic compatibility, the capacity of an apparatus, plant or system to work satisfactorily in an electromagnetic environment, without causing electromagnetic interference itself that would be unacceptable for the apparatus, plants or system in this setting.

Gas discharge tube, GDT

Gas-filled surge protective device

Insertion loss

The attenuation value is defined as the ratio of voltages that occur immediately before and after the insertion point of the protective device to be tested. The result is expressed in decibels.

Lightning Protection Level

A regulatory division of lightning protection systems into classes I to IV, which are based on a set of lightning

current parameter values with regard to probability, whereby the largest and smallest measured values in the event of naturally occurring strikes cannot be exceeded and the strikes can be safely discharged. Lightning Protection Level I thereby corresponds to the highest measured values and the greatest probability of capturing a strike. The values decrease accordingly, down to Lightning Protection Level IV.

Lightning protection system

System consisting of interception rods, protective devices, and grounding system externally, as well as equipotential bonding system and coordinated SPD system within the structural system to protect against damage caused by surge voltages and surge currents from lightning strikes.

Lightning protection zone

A zone in which the electromagnetic environment is determined with regard to risk of lightning. All the (supply) lines that cross zone limits must be included in the lightning protection equipotential bonding by means of corresponding SPDs. The zone limits of a lightning zone are not necessarily physical limits (e.g., walls, floor or ceiling).

Lightning protection zone, LPZ

Lightning protection zone

Maximum continuous voltage (U_c)

Maximum r.m.s. value of the voltage that can continuously be applied to the mode of protection of the SPDs. The maximum continuous voltage must be at least 10% higher than the value of the nominal voltage. In systems with greater voltage fluctuations, SPDs with a greater difference between U_c and U_N must be used.

Nominal discharge current (I_n)

Peak value of the current flowing through the SPD with pulse shape (8/20 μ s). The pulse shape (8/20 μ s) of a surge current is characteristic of the effects of an indirect lightning strike or switching operation. The value of the nominal discharge current is used for a variety of tests on an SPD, including those used to determine the voltage protection level. Depending on the Lightning Protection Level assigned to a lightning protection system, the SPDs must have minimum values that correspond to this value.

Nominal load current (I_L)

Maximum r.m.s. value of the nominal current, which allows a connected ohmic load to flow to one of the protected outputs of the SPD. This maximum value is specified by the parts carrying operational current within the SPDs; these must be able to withstand the continuous thermal current load.

Nominal voltage (U_N)

The nominal value of the voltage of the current or signal circuit based on the use envisaged for the SPDs. The nominal voltage stated for an SPD corresponds to the system voltage of the typical SPD installation site for a standard three-phase system, e.g., 230/400 V AC. Lower system voltages can also be protected by the SPD. In the event of higher system voltages, it must be decided on a case-to-case basis as to whether the SPD can be used and if there are restrictions to observe.

Off-load voltage (U_{OC})

Off-load voltage of the hybrid generator at the terminal points of the SPD. A hybrid generator creates a combined

surge; e.g., in off-load, it supplies a voltage pulse with a defined pulse shape, generally (1.2/50 μ s), and in a short circuit, a current pulse with a defined pulse shape, generally (8/20 μ s). The combined surge is characteristic of the effects of an induced surge voltage. Depending on the protection class assigned to a lightning protection system, the SPDs must have minimum values that correspond to this value.

Overcurrent protective device, OCPD

Overcurrent protective device

Power over Ethernet, PoE

Power over Ethernet is a process in which the auxiliary energy for the connected devices is also transmitted via the Ethernet data cable.

Pulse discharge current (I_{imp})

Peak value of the current flowing through the SPD with pulse shape (10/350 μ s). The pulse shape (10/350 μ s) of a surge current is characteristic of the effects of a direct lightning strike. The value of the pulse discharge current is used for special SPD tests to demonstrate carrying capacity with regard to high-energy lightning currents. According to the Lightning Protection Level assigned to a lightning protection system, the SPDs must have minimum values that correspond to this value.

Safe Energy Control technology, SEC technology

Technology for SPDs for protecting the power supply. SPDs with SEC technology are characterized by the following:

- Impact-free and durable
- Backup-fuse-free solution for every application
- Compact and consistent pluggable design

Sequential current extinguishing capacity (I_{fi})

The sequential current extinguishing

capacity indicates the prospective r.m.s. value of the short-circuit current at the installation location of a voltage-switching SPD, up to which the SPD once again transitions into a high ohmic state if the maximum U_c continuous voltage is being independently applied due to a surge current, without triggering an upstream overcurrent protective device.

Short-circuit withstand capability (I_{SCCR})

Maximum uninfluenced short-circuit current of the electrical network, for which the SPD is rated in conjunction with the upstream overcurrent protective device. The short-circuit withstand capability indicates up to which prospective short-circuit current the SPD can be used at the installation location. The corresponding tests to determine this value are carried out in connection with the upstream overcurrent protective device. In the event that the special surge protective devices for PV systems correspond to the value I_{SCPV} , this is the max. direct current short-circuit current of a system up to which the the SPD may be used.

Surge current

A pulse-shaped current that is characterized by a significant rise in current within a short period of time. Typical pulse shapes are (8/20 μ s), with which the voltage-limiting behavior of SPDs can be checked, and (10/350 μ s), with which the lightning current capacity of the SPDs can be tested.

Surge protective device, SPD

Surge protective device

Surge voltage

A pulse-shaped voltage that is characterized by a significant rise in voltage within a short period of time. A typical pulse shape is (1.2/50 μ s). The response behavior of SPDs or the surge voltage resistance of equipment can also be tested with this.

TVS

TVS stands for Transient Voltage Suppressor.

Overvoltage category Division of equipment into categories I to IV depending on their surge voltage resistance. Overvoltage category I corresponds to the lowest value and consists of particularly sensitive (end) devices. These values increase accordingly, up to overvoltage category IV. The values for the individual categories also depend on the voltage level of the power supply system.

Voltage protection level (U_p)

Maximum voltage that can occur on the connection terminal blocks of the SPD while loaded with a pulse of specific voltage steepness and a discharge surge current of specified amplitude and wave form. This value characterizes the surge voltage protective effect of the SPD. In the event of a surge voltage phenomenon within the performance parameters of the SPDs, the voltage is safely limited to a maximum of this value at the protected connections of the SPD.

8

References

- [1] International Electrotechnical Commission. IEC 62305-1 - Lightning protection - Part 1: General principles. s.l. : VDE Verlag GmbH, 2010.
- [2] International Electrotechnical Commission. IEC 62305-2 - Lightning protection - Part 2: Risk management. s.l. : VDE Verlag GmbH, 2010.
- [3] International Electrotechnical Commission. IEC 62305-3 - Lightning protection - Part 3: Physical damage to structures and life hazard. s.l. : VDE Verlag GmbH, 2010.
- [4] International Electrotechnical Commission. IEC 62305-4 - Lightning protection - Part 4: Protection against lightning. Electrical and electronic systems within structures. s.l. : VDE Verlag GmbH, 2010.
- [5] International Electrotechnical Commission. IEC 60364-4-44 - Low-voltage electrical installations - Part 4-44: Protection for safety - Protection against voltage disturbances and electromagnetic disturbances. s.l. : VDE Verlag GmbH, 2007.
- [6] International Electrotechnical Commission. IEC 61643-11 - Surge protective devices connected to low-voltage power systems - requirements and test methods. s.l. : VDE Verlag GmbH, 2011.
- [7] International Electrotechnical Commission. IEC 61643-21 - Surge protective devices connected to telecommunications and signaling networks - Performance requirements and testing methods. s.l. : VDE Verlag GmbH, 2000.
- [8] International Electrotechnical Commission. IEC 61643-31 - Low-voltage surge protective devices – requirements and tests for surge protective devices to be used in photovoltaic installations. s.l. : VDE Verlag GmbH, 2015.
- [9] International Electrotechnical Commission. IEC 60664-1 - Insulation coordination for equipment within low-voltage systems - Part 1: Principles, requirements, and tests. s.l. : VDE Verlag GmbH, 2007.
- [10] International Electrotechnical Commission. IEC 60364-1 - Low-voltage electrical installations - Part 1: Fundamental principles, assessment of general characteristics, definitions. s.l. : VDE Verlag GmbH, 2005.
- [11] International Electrotechnical Commission. IEC 60364-5-53 - Electrical installations of buildings - Part 5: Selection and erection of electrical equipment; Section 53: Switchgear and control. s.l. : VDE Verlag GmbH, 2002.
- [12] International Electrotechnical Commission. IEC 60364-4-43 - Low-voltage electrical installations - Part 4-43: Protection for safety - Protection against overcurrent. s.l. : VDE Verlag GmbH, 2008.
- [13] European Committee for Electrotechnical Standardization. CLC/TS 50539-12 - Low-voltage surge protective devices connected to photovoltaic installations - Selection and application principles. s.l. : VDE Verlag GmbH, 2013.
- [14] Phoenix Contact GmbH & Co. KG. TRABTECH surge protection - user manual for specialist electrical planners. 2015.
- [15] International Electrotechnical Commission. IEC 61643-12 - Surge protective devices connected to low-voltage power systems - Selection and application principles. s.l. : VDE Verlag GmbH, 2010.
- [16] International Electrotechnical Commission. IEC 61643-22 - Low-voltage surge protective devices - Surge protective devices connected to telecommunications and signaling - Selection and application principles. s.l. : VDE Verlag GmbH, 2007.



Always up-to-date, always available to you. Here you'll find everything on our products, solutions and service:
phoenixcontact.com

Product range

- Cables and wires
- Connectors
- Controllers
- Electronics housings
- Electronic switchgear and motor control
- Fieldbus components and systems
- Functional safety
- HMIs and industrial PCs
- I/O systems
- Industrial communication technology
- Industrial Ethernet
- Installation and mounting material
- Lighting and signaling
- Marking and labeling
- Measurement and control technology
- Monitoring
- PCB terminal blocks and PCB connectors
- Power supply units and UPS
- Protective devices
- Relay modules
- Sensor/actuator cabling
- Software
- Surge protection and interference filters
- System cabling for controllers
- Terminal blocks
- Tools
- Wireless data communication

PHOENIX CONTACT GmbH & Co. KG
Flachmarktstraße 8
32825 Blomberg, Germany
Phone: + 49 5235 3-00
Fax: + 49 5235 3-41200
E-mail: info@phoenixcontact.com
phoenixcontact.com



INSPIRING INNOVATIONS